

CITY OF ROSLYN

KITTITAS COUNTY

WASHINGTON



CONSTRUCTION STANDARDS

G&O #23867
OCTOBER 2024



Gray & Osborne, Inc.
CONSULTING ENGINEERS

TABLE OF CONTENTS

CHAPTER 1 – GENERAL REQUIREMENTS

Requirements for Developer Constructed Improvements

CHAPTER 2 – WATER

- W-1 Water Main Pipe
- W-2 Water Main Fittings
- W-3 Valves
- W-4 Tapping Tees and Tapping Valves
- W-5 Air Relief Valves
- W-6 Blowoff Assemblies
- W-7 Fire Hydrants
- W-8 Service Connections
- W-9 Large Meter and Tests
- W-10 Hydrostatic Pressure Test
- W-11 Disinfection of Water Mains
- W-12 Connection to Existing Systems

CHAPTER 3 – STORM

- SD-1 Storm Drain Piping
- SD-2 Catch Basins
- SD-3 Precast Concrete Dry Wells
- SD-4 Rings and Covers
- SD-5 Steps
- SD-6 Frames and Grates
- SD-7 Beehive Frame
- SD-8 Gaskets and Manhole Adapters
- SD-9 Infiltration Trench
- SD-10 Televised Inspection

CHAPTER 4 – SEWER

- S-1 Sewer Mains, Laterals and Force Mains
- S-2 Manholes
- S-3 Testing Gravity Sewers
- S-4 Testing Force Mains
- S-5 Televised Inspection
- S-6 Collection System Pump Stations

CHAPTER 5 – STREETS

- ST-1 Excavation and Subgrade Preparation
- ST-2 Roadway Construction
- ST-3 Concrete Curbs and Pedestrian Facilities
- ST-4 Street Classifications
- ST-5 Street Lighting

STANDARD DETAILS

CHAPTER 1
GENERAL REQUIREMENTS

REQUIREMENTS FOR DEVELOPER CONSTRUCTED IMPROVEMENTS

Section A: General Provisions

1. The specifications and standard details provided herein shall be used to implement design and construction requirements of the City of Roslyn development ordinances, codes, or titles. The use of product manufacture names or trademarks is intended to provide examples of acceptable quality standards. Parts or products specified by name may be interchangeable with like and equal products only upon prior City approval.
2. Definitions for terms described herein shall be those provided pursuant to Title 13 of the Roslyn Municipal Code. The definition of any word or phrase which may not be identified pursuant to Title 13 shall be defined from either one of the following sources:
 - A. Revised Code of Washington.
 - B. Washington Administrative Code.
 - C. Commonly used dictionary such as Merriam-Webster's.
3. Within this document are numerous references to "the City". All communication with the City shall be first directed to the City of Roslyn Public Works Director. The Public Works Director may designate an alternate contact for specific items, however only the Public Works Director shall have the authority to provide approval for variations from this document.

Section B: General Requirements of the Developer

1. The Developer shall retain the services of a Professional Engineer licensed in the state of Washington to provide necessary construction design services.
2. Complete plans and specifications of any proposed improvement shall be submitted to the City for approval. Upon City review and approval, the Developer shall submit all water and sewer plans and specifications to the Departments of Health and Ecology.
3. Unless otherwise approved by the City, plan and design drawings shall have a minimum scale of 1 inch equal to 50 feet, or, 1 inch equal to 40 feet if water, sewer, and street improvements are drawn on the same sheets.

4. All utilities, whether City-owned or provided by an outside purveyor, shall be placed within the City's required right-of-way.
5. Water and sewer certification shall be on standard State forms. Copies of testing data including, but not limited to, compaction and pressure testing, shall be provided to the City. Street certification shall consist of a letter, test data, weigh tickets, and other associated or City required information.
6. The Developer shall provide a performance bond or similar security instrument to ensure workmanship and materials over the full time period between project beginning and end.
7. The Developer shall require the Contractor to provide insurance which insures all contracted work and which holds the City and its agents harmless from any and all damage claims which may result due to the performance of any contracted work. The Contractor shall provide the City proof of insurance which shall be approved by the City prior to commencing contracted work.
8. The Developer shall provide the City with a mylar copy of construction record drawings illustrating all revisions made during construction. At minimum, the record drawings shall show the following:
 - A. The existence of all underground utilities encountered (station and depth).
 - B. Precise distance to fittings, valves, services, etc., length of all spools, etc.
 - C. Type of all fitting ends (MJ, FL, etc.).
 - D. Type of restraint used.
 - E. Location of sewer wyes.
 - F. Elevation of each manhole, pipe invert (in and out) and sewer slope.
9. Where specific manufacturers are required for facilities and materials, installation of those facilities and materials shall be completed to the manufacturer's specifications, unless otherwise approved by the City.
10. No excavation work shall be done between November 15 and February 15 without permission from Roslyn Public Works.
11. Water system improvements shall meet the requirements of the Washington State Department of Health Water System Design Manual, current edition, and the specifications as described herein.

12. Sewer system improvements shall meet the requirements of the Washington State Department of Ecology Criteria for Sewerage Works Design, current edition, and the specifications as described herein.
13. The storm drainage standards established herein are intended to represent the minimum standards for the design and construction of storm drainage facilities. Greater or lesser requirements may be mandated by the City due to localized conditions. Storm drainage revisions, additions, modifications, or changes shall be made in compliance with City standards, ordinances, and Best Management Practices as identified in the Washington State Department of Ecology Stormwater Management Manual for Eastern Washington, hereinafter referred to as "Stormwater Manual." Adequate provisions shall be made for storm drainage, storm sewers, and associated appurtenances sufficient to transmit maximum runoff from the 25-year, 24-hour event. All storm drainage facilities shall be designed by a professional engineer licensed in the State of Washington and shall comply with the Stormwater Manual.

If warranted based on the condition and capacity of the existing storm drainage infrastructure (or lack thereof) and impacts caused by the proposed development, off-site improvements may be required, at the City Engineer's discretion, to mitigate impacts caused by the proposed development.

14. All work and materials for public infrastructure improvements to be dedicated to the City shall be in accordance with the current edition of the City of Roslyn Municipal Code, Construction Standards, and the Washington State Department of Transportation (WSDOT) Standard Specifications for Road, Bridge, and Municipal Construction.

END CHAPTER 1

CHAPTER 2

WATER

W-1 WATER MAIN PIPE

Water mains to be installed shall be polyvinyl chloride (PVC) for all sizes unless specifically noted otherwise.

The PVC pipe shall conform to AWWA C900 Standards. The PVC pipe shall have the same outside dimensions as ductile iron pipe and shall be a minimum of SDR 18.

The pipe manufacturer shall certify in writing that the inspection and all tests of the specified standards for both pipe and gaskets being supplied for this project have been made and that the results thereof comply with the requirements of the AWWA standard.

Joints shall be “made-up” in accordance with the manufacturer’s recommendations. Standard joint material, including rubber ring gaskets, shall be furnished with the pipe. Materials shall be suitable for the specified pipe sizes and pressures.

Except where necessary, in making connections with other lines and unless authorized by the City, pipes shall be laid with bells facing in the direction of laying and for lines on an appreciable slope, the bells shall face upwards.

Department of Health (DOH) and Department of Ecology (DOE) standards for horizontal and vertical separation from any utility with the potential to contaminate the water system shall be maintained. If the required separation cannot be maintained, mitigation such as a sleeve or encasement shall be provided. See DOH’s *Water System Design Manual*, DOE’s ‘Orange Book,’ *Criteria for Sewage Works Design*, and any additional reference materials published by DOH or DOE.

All pipe shall be delivered to the job site with water-tight wrapping or pipe plugs. All pipe shall be carefully checked on delivery as well as before placing in the trench. The pipe shall be carefully bedded, joined, and protected. It shall be laid to the line and grade established and at all times the interior kept free from dirt, gravel, and all other foreign matter. The open ends shall be wrapped or plugged and secured at any time pipe laying is not in progress.

Water mains shall be laid on a uniform grade and the Developer shall anticipate those places where additional depth is required to avoid certain utilities and adjust the pipeline profile accordingly to maintain a uniform grade.

Prior to making permanent connections to the existing system, the new water main including service lines shall have been disinfected according to AWWA

C-651 standards, passed a pressure test, been adequately flushed, and finally passed the required bacteriological test.

Dirt or other foreign material shall be prevented from entering the pipe or pipe joint during handling or laying operations, and any pipe or fitting that has been installed with dirt or foreign material in it shall be removed, cleaned, and relayed. A clean whiskbroom shall be used for this purpose and for brushing to remove foreign matter prior to joining pipe ends. At times when pipe laying is not in progress, the open ends of the pipe shall be closed by a watertight plug or by other means approved by the City to ensure cleanliness inside the pipe.

Pipe shall be stacked in such a manner as to prevent damage to the pipe, to prevent dirt and debris from entering the pipe, and to prevent any movement of the pipe. The bottom tiers of the stack shall be kept off the ground on timbers, rails, or other similar supports. Pipe on succeeding tiers shall be alternated by bell and plain end. Timbers 4 inches by 4 inches in size shall be placed between tiers and chocks shall be placed at each end to prevent movement. For safety, each size of pipe shall be stacked separately.

W-2 WATER MAIN FITTINGS

All fittings shall be short-bodied, ductile iron complying with applicable AWWA C110 or C153 Standards. All fittings shall be cement-lined and either mechanical joint or flanged, as indicated on the Plans. Use of a comparable "equal" product requires approval of the City.

Fittings in sections shown on the Plans requiring restrained joints shall be mechanical joint fittings with a mechanical joint restraint device. The mechanical joint restraint device shall have a working pressure of at least 250 psi with a minimum safety factor of 2:1 and shall be EBAA Iron, Inc. MEGALUG, Romac Industries, Inc., Grip Ring Pipe Restrainer, or approved equal. Stargrip Series 3000 mechanical joint restraint devices are not accepted or approved as equal.

Fittings shall be adequately "blocked" with poured-in-place concrete, within wooden forms shaped to establish a firm minimum bearing area, against an undisturbed earth wall as shown on the Standard Details. 4" x 4" minimum size Timber blocking may be permitted as temporary blocking, when utilized as forms outside the poured-in-place concrete when fittings are to be pressurized prior to the 24-hour minimum "set" time. The concrete thrust blocks must be in place at least 24 hours before beginning the pressure test, to allow the concrete to "set". The strength of the concrete shall be 2,000 psi minimum.

All valves and all fittings requiring a concrete block shall first be covered with visqueen before concrete is poured. The concrete shall not cover joints, bolt heads, or nuts.

All bolts shall be coated with Armitite Anti-Seize Compound No. 609, or equal, prior to installation.

Before cutting existing pipes, the Developer shall measure the pipe outside diameter to determine if the pipe was manufactured to a diameter that is different than presently specified in AWWA Standards, and if required, the Developer shall furnish alternate or additional fittings more compatible with the pipe outside diameter.

All connections to other pipe shall be with Romac, Smith-Blair, Dresser, or Ford flexible couplings. The couplings shall have long middle rings and shall have a fusion-bonded epoxy coating. Coupling gaskets shall be Grade 60. The bolts and nuts shall be high-strength, low-alloy steel, or electro-galvanized mild steel.

All joints in the pipe, fittings, valves, flexible couplings, and sleeves, shall be fully seated with small clearances allowed for pipe expansion. Where flexible couplings and sleeves are called for, the space between pipe ends shall not exceed 1/4 inch.

When the space between pipe ends is excessive, a short section of pipe may be inserted as a spacer ring to limit such pipe movement within the coupling or sleeve, to obtain the 1/4-inch limitation stipulated herein.

W-3 VALVES

All valves 12 inches and smaller shall be resilient seated ductile iron gate valves except where shown on the Plans. All valves 16 inches and larger shall be ductile iron butterfly valves.

Valves shall be installed at a minimum of every 800 lineal feet of pipe installed in residential areas and a minimum of every 500 lineal feet in commercial/industrial areas.

The valve manufacturer shall certify in writing that the inspection and all tests of the specified standards for the valves being supplied for this project have been made and that the results thereof comply with the requirements of the Standard.

A. Resilient-Seated Gate Valves

The gate valves shall be resilient seated ductile iron body valves with non-rising stems (NRS) opening counterclockwise and equipped with a 2-inch square operating nut. Valves shall meet the full requirements of the AWWA C509 or C515 Standards. The valves shall have double "O" ring stem seals which shall withstand the test pressure without leakage. Valves shall be rated at 250 pounds

per square inch (psi), minimum working pressure and furnished with either flanged and/or mechanical joints as shown on the Plans. All surfaces, interior and exterior, shall be epoxy-coated, acceptable for potable water.

Valves shall be Mueller, M&H, Clow, American Flow Control Series 2500, U.S. Pipe, or approved equal.

B. Butterfly Valves

The butterfly valves shall be either mechanical joint or flanged ductile iron body valves equipped with a 2-inch square operating nut and shall be of the tight closing, rubber seat type. Valves shall meet the full requirements of AWWA C504-87 Standards, Class 150-B except the valve shall be able to withstand 200 psi differential pressure without leakage.

Butterfly valves shall be Mueller, M&H, Clow, Henry Pratt Company "Groundhog," or approved equal.

C. Appurtenances

All valves shall be set with the operating stems vertical. The axis of the valve box shall be common with the projected axis of the valve operating stem. The tops of the adjustable valve boxes shall be set to the existing or established grade, whichever is applicable.

Valves shall include operator extension stems to bring the operating nut from 2'-0" to 1'-6" from finished grade.

The extension stem of the length required to meet field conditions shall be a manufactured unit with a 1-inch-diameter mild steel rod. At the top of the extension stem, there shall be a 2-inch standard operating nut complete with a centering flange.

Valve boxes shall be equal to the "Rich 940" Model or Sather Manufacturing. The flared end of the valve box shall be set at the bottom elevation of the 2-inch operating nut to allow space for rocks to be moved laterally from the operation nut. The "ears" on the valve box top shall be aligned parallel in the direction of the branch the valve opens and closes.

The valve box shall be placed over the valve or valve operator in such a manner that the valve box does not transmit shock or stress loads to the valve. The casting shall not rest directly upon the body of the valve or upon the water main.

Any extension of the valve box shall utilize additional flared end valve box bottom sections or cast iron hub soil pipe. Other materials are not acceptable.

In areas where the valve box is not in concrete or asphalt a 24-inch-diameter by 6-inch asphalt block shall be installed around the valve box at finished grade in paved areas and cement concrete block shall be utilized in unpaved areas. The valve box shall be flush with the top and centered.

A fiberglass valve marker post shall be furnished and installed where directed. Valve marker posts shall be blue in color, 3.75 inches wide (flat), 60 inches long and furnished with a 3-inch-by 3-inch-high density white reflector (250 candle power) and a flexible anchor barb. Valve markers shall be Carsonite Utility Marker CUM 375.

Markers shall be placed at the edge of the right-of-way opposite the valve and set so as to leave 36 inches of the post exposed above grade. The size of the valve and the distance in feet and inches to the valve shall be noted with decals, typically designed for use on fiberglass boats, placed on the face of the post, using letters approximately 2 inches high. Each post shall include the following decal: "Caution Water Valve, Before Digging, Call 811, Utility Underground Location Center."

W-4 TAPPING TEES AND TAPPING VALVES

The tapping sleeves shall be rated for a working pressure of 250 psi minimum and furnished complete with joint accessories. Tapping sleeves shall be constructed in two sections for ease of installation and shall be assembled around the main without interrupting service.

Fabricated steel style sleeves shall be fusion bonded coated, acceptable for potable water, and shall be manufactured by JCM, Romac, or approved equal.

Size on size tapping shall not be permitted.

Tapping valves shall be resilient-seated ductile iron body gate valves provided with a standard mechanical joint outlet for use with ductile iron pipe and shall have oversized seat rings to permit entry of the tapping machine cutters. In all other respects, the tapping valves shall conform to the resilient seat gate valves herein specified with regards to operation and materials.

The tapping sleeve and valve shall be pressure tested to 200 psi (water) prior to tapping the main.

The installation of the tapping sleeves and valves and the tapping of the main shall be performed by Speer Taps or an equal approved by the City.

W-5 AIR RELIEF VALVES

Air and vacuum release assemblies shall be installed at high points on the water system as shown on the Plans or designated in the field by the City.

The air relief assemblies shall be a combination air and vacuum valve APCO 143C or equal complete as shown on the Standard Detail.

W-6 BLOWOFF ASSEMBLIES

The blowoff assemblies shall be furnished and installed as shown on the Standard Detail.

Temporary blowoffs utilized by the Contractor for flushing the water main shall be sufficient size to obtain 2.5 feet per second velocity in the main.

Hydrant assemblies shall be installed within 4 feet of new dead-end water mains before being placed in service. Blow-off assemblies may be approved by the City in lieu of hydrant assemblies for temporary dead-end water mains that are to be placed in service. Blow-off assemblies are not approved for installation on dead-end water mains within permanent cul-de-sacs.

W-7 FIRE HYDRANTS

The fire hydrants shall be the break-away compression type, meeting AWWA C502-85 Standards, in which the valve will remain closed if the barrel is broken. The hydrant's main valve opening shall be not less than 5-1/4 inches in diameter. The fire hydrants shall be equipped with two, 2-1/2-inch National Standard Thread (NST) hose nozzles and one, 4-1/2-inch NST pumper port. A permanent anodized 5-inch Storz hydrant adapter and anodized Storz blind flange shall be installed on the 4-1/2-inch pumper port. Branch connection shall be for 6-inch pipe, as noted on the Standard Details, and shall be mechanical joint.

Fire hydrants shall be M&H Model 129, or approved equal.

Fire hydrant spacing shall not exceed 400 feet. Additional hydrants may be required to provide adequate fire protection as noted in Section C103 of the *International Fire Code*.

The Contractor shall furnish fire hydrants with the correct bury depth (trench depth), in accordance with the specified pipe depth and special conditions of the Project. The fire hydrants shall be installed to provide the mounting height above finished grade as shown on the Standard Detail. The hydrant shall be installed plumb on the vertical axis.

The hydrants shall be wire brushed, primed with one coat of Preservative All Metal Guard II and painted with two coats of Yellow to match the City's existing hydrants.

Between the time that the hydrant is installed and the completed facility is placed in operation, the hydrant shall at all times, be wrapped in burlap, bagged, or covered in some other suitable manner as approved by the City, to clearly indicate that the hydrant is not in service.

The resilient, seated ductile iron body gate valve shall have a flange by mechanical joint body, and be bolted to the main line tee.

The connecting pipe between the fire hydrant and gate valve shall be 6-inch Cl. 52 ductile iron pipe and shall not exceed 50 feet in length. The fire hydrant and gate valve shall be restrained with a mechanical joint restraint device as indicated in Water Main Fittings. In addition to this, the hydrant and tee shall be fully blocked with concrete.

W-8 SERVICE CONNECTIONS

Individual services to each structure and/or property shall be installed and connected to the new water mains. All materials shall be lead-free in compliance with NSF 61.

The Developer shall inquire with the City regarding typical water pressure in the vicinity of the proposed development. The Developer is responsible for providing means to accommodate any high or low pressures provided from the City's system. Pressure reducing valves, booster pumps, or other equipment may be installed at the Developer's option, or required at the City's discretion, in order to meet DOH standards for distribution system pressures.

Upon completion of the installation of the water main (before testing and disinfection) services shall be installed by connecting to the water main and extending the service line to the property line as shown on the Standard Details or approved equal. Service lines for residential property shall be 1-inch 1-inch SDR9 CTS PE4710 ASTM D-2737, AWWA 901, NSF 61 certified. Larger service lines shall be of the type and style as designated in the Standard Details and shown on the Plans.

Two inch and smaller meters are supplied by the City. Three inch and larger meters fall into a different design criteria and shall be specifically coordinated with the City.

Corporation stops and the single meter shut-off valves shall be "Mueller" of the type and style noted on the Standard Details or approved equal. Included as a

part of the service connection shall be the furnishing and installation of the meter box complete with a cast iron traffic lid, set flush with the proposed finished grade of the lot in the designated location near the property line, all as shown on the Standard Details.

Service lines between the main and the property line shall be placed at a trench depth sufficient to maintain cover over the top of the service line per the standard detail for its full length, taking into consideration the final finished grade of the proposed street and the final finished grade of any storm ditches.

W-9 LARGE METER AND TESTS

If extensions require water meters 3 inches or larger, then such entire meter installations, including but not limited to, valves, piping, vaults, drain lines and meters shall be coordinated with City staff.

W-10 HYDROSTATIC PRESSURE TEST

The water mains shall be hydrostatically tested before being placed in service. Water for testing must be obtained by the Developer by arrangement with the City. A positive displacement type pump shall be furnished by the Developer for the testing. Feed for the pump shall be from a disinfected clean container, wherein the actual amount of "makeup" water can be measured.

Upon completion of sections of the pipe installation, the water main shall be pressure tested in segments of 1,000 lineal feet or less. The test pressure shall be either 200 pounds per square inch, or twice the system pressure, using the greater value, and shall maintain the test for a period of not less than 2 hours.

Pressure testing against existing valves shall not be permitted unless authorized by the City.

The Developer shall provide temporary plugs, caps and blocking as required to pressure test and disinfect the new water main prior to making connections to the existing system.

Concrete thrust blocking for fittings shall be in place and the concrete "set" sufficiently to withstand the test pressure before starting the test.

All pressure tests shall be made with the hydrant auxiliary gate valves open and pressure against the hydrant valve. After this basic pipe line test has been completed, each valve shall be tested including the hydrant auxiliary valve by closing each in turn and relieving the pressure beyond. This test of the valves will be acceptable if there is no immediate loss of pressure on the gauge when the pressure comes against the valve being checked. The Developer shall verify

and assure that the pressure differential across the valve does not exceed the rated working pressure of the valve.

Prior to calling for the City to witness the pressure test, the Developer shall first perform a satisfactory pressure test. The allowable leakage rate per thousand feet of each size pipeline is as follows:

<u>Pipe Size</u>	<u>Allowable Leakage Gallon per hour per 1,000 Ft. @ 200 psi</u>
6"	3.8 oz.
8"	6.7 oz.
10"	10.5 oz.
12"	15.1
14" and Larger	D ² x 15.1

Any leakage caused by defective workmanship or materials shall be repaired, and the line shall again be tested to full compliance.

All visible leaks in pipelines or fittings shall be repaired even if the test results fall within the allowable leakage.

W-11 DISINFECTION OF WATER MAINS

Water mains and appurtenances shall be disinfected in accordance with AWWA C651 before being placed in service. Water for disinfection must be obtained by the Developer by arrangement with the City.

The method of placing calcium hypochlorite granules in the water main as it is being installed is acceptable if the pipe and appurtenances are kept clean and dry during construction.

The calcium hypochlorite granules contain approximately 65 percent available chlorine by weight. The minimum amount of calcium hypochlorite granules placed at the beginning and in each 500 feet of pipe is as follows:

<u>Pipe Size</u>	<u>Calcium Hypochlorite Granules</u>
6"	1.0 oz.
8"	2.0 oz.
12"	4.0 oz.
16" and larger	8.0 oz.

When the line is completed and ready to disinfect, water shall be allowed to flow in slowly, until it appears at the far end of the line so as not to displace the disinfecting agent. The system shall then be allowed to stand for at least

24 hours. The line shall then be flushed through the fire hydrants until a test shows the chlorine residual no longer exceeds distribution system residual.

In all instances, the Developer shall utilize a state-approved double check valve type backflow prevention device to protect the potable water supply while filling, flushing, and disinfecting the particular water main.

In the process of chlorinating newly laid water pipe, all valves, fire hydrants, and other appurtenances shall be operated while the pipeline is filled with the chlorinating agent.

The Developer is herein advised that prior to making any restoration or permanent connections to the existing water mains the Developer shall first demonstrate to the City that the new water main has adequately passed a pressure test, been adequately flushed, and finally passed the required bacteriological test.

In all disinfection processes, the Developer shall take particular care in flushing and wasting the chlorinated water from the mains to assure that the flushed and chlorinated water does no physical or environmental damage to property, streams, storm sewers or any waterways. Flushing water must be disposed of in accordance with Washington State Department of Ecology Standards. Flushing water shall require dechlorination or disposal to sewer system to prevent damage to the affected environment, particularly aquatic and fish life of receiving streams.

Before placing the lines in service, a satisfactory bacteriological report or approval shall be received from a State approved laboratory on samples collected from representative points in the new system. The City shall collect all samples for the bacteriological tests. However, the Developer shall notify the City requesting collection of samples 2 working days in advance, and schedule on days wherein samples can be conveniently processed by a State Department of Health approved laboratory. If any of the pipeline materials are replaced thereafter, then that section shall again be disinfected, pressure tested and tested for bacteriological count.

If disinfection of mains by the above methods prove unsatisfactory and the lab report indicates any type of bacteria count, then the Developer shall re-chlorinate using other methods in accordance with AWWA C691, approved by the City.

W-12 CONNECTIONS TO EXISTING SYSTEMS

All cut-in connections to the existing system shall be made after a successful pressure test of the new main has been witnessed by the City and after a purity test has been satisfactorily evidenced.

Size on size taps shall not be permitted.

Where it is necessary to shut-off the existing (or new) mains to make a connection, the Developer shall notify the City 72 hours or 3 working days in advance of such shut-off, and the City will notify customers of the shut-off, provide temporary services to critical customers and shut-off the mains. Connections shall be performed between the hours of 9:00 a.m. and 4:30 p.m. only. No cut-in connections or connections of new piping to the existing piping shall be scheduled for Fridays or Mondays. Once the water has been shut-off, the Developer shall diligently pursue the connection to completion, so that the time required for the shut-off may be held to a minimum. The City will notify customers in the area of the scheduled shut-off.

The required connections shall not be started until all of the materials, equipment and labor necessary to properly complete the work are assembled on the site. All connections shall be completed the same day they are started. The Developer shall time its operations so that water will not be shutoff overnight or over weekends or holidays.

It shall be the responsibility of the Developer to determine the exact horizontal and vertical location of connections, ascertain the type and size of existing facilities and determine potential conflicts prior to starting work on any connection. Alternatives shall be provided as required to complete the connection detail.

Connections to existing facilities shall be made with the use of fittings, valves, flexible couplings, solid sleeves, shackling and other miscellaneous fittings, including thrust blocks as shown on the Plans and with additional pipe or fittings as approved by the City.

Where connections are made to existing facilities and it is impractical to use the methods described herein to disinfect the section between the existing water main and the point of installation of the new water main (valve or temporarily plugged line) the Developer shall clean and swab the pipe, fittings and valves with a minimum 5 percent chlorinated solution immediately before making said connection and thereby disinfect the necessary connection.

All pipe and fittings used for the connection shall be clean and disinfected. The Developer shall take extra precautions to ensure the tightness of the connections, nuts and bolts. The existing water main shall be placed back into service by the City and the connection observed for leakage by the City prior to backfilling the pipe.

END CHAPTER 2

CHAPTER 3

STORM

SD-1 STORM DRAIN PIPING

Storm Drain pipe shall be corrugated polyethylene pipe (CPEP) or polyvinyl chloride (PVC) unless specifically noted otherwise.

All materials delivered to the job site shall be new, free from defects, and marked to identify the material, class, and other appropriate data such as thickness for piping.

Acceptance of materials shall be subject to strength and quality testing in addition to inspection of the complete product. Acceptance of installed piping systems shall be based on inspection and leakage tests.

All types of pipe shall be handled in a manner that will prevent damage to the pipe.

Dirt or other foreign material shall be prevented from entering the pipe or pipe joint during handling or laying operations, and any pipe or fitting that has been installed with dirt or foreign material in it shall be removed, cleaned, and relayed. A clean whiskbroom shall be used for this purpose and for brushing to remove foreign matter prior to joining pipe ends. At times when pipe laying is not in progress, the open ends of the pipe shall be closed by a watertight plug or by other means approved by the Owner to ensure cleanliness inside the pipe.

Pipe shall be stacked in such a manner as to prevent damage to the pipe, to prevent dirt and debris from entering the pipe, and to prevent any movement of the pipe. The bottom tiers of the stack shall be kept off the ground on timbers, rails, or other similar supports.

All bell and spigot connections shall be made up in strict compliance with the manufacturer's recommendations and all sewer pipe manufacture and handling shall meet or exceed the ASTM and SPAW recommended specifications.

Pipe handling after the gasket has been affixed shall be carefully controlled to avoid disturbing the gasket and knocking it out of position, or loading it with dirt or other foreign material. Any gaskets so disturbed shall be removed, cleaned, relubricated if required, and replaced before the rejoining is attempted.

Care shall be taken to properly align the pipe before joints are entirely forced home. During insertion of the tongue or spigot, the pipe shall be partially supported by hand, sling, or crane to minimize unequal lateral pressure on the gasket and to maintain concentricity until the gasket is properly positioned. Since most flexible gasketed joints tend to creep apart when the end pipe is deflected

and straightened, such movement shall be held to a minimum once the joint is home.

Sufficient pressure shall be applied in making the joint to ensure that it is home, as described in the installation instructions provided by the pipe manufacturer. Sufficient restraint shall be applied to the line to ensure that joints once home are held so until fill material under and alongside the pipe has been sufficiently compacted.

A. CPEP Pipe and Fittings

Corrugated polyethylene pipe (CPEP) and fittings shall conform to the requirements of AASHTO M-252 and AASHTO M-294, Type S. Fittings shall be as shown on the Plans and as required to provide a complete piping system and meet the same requirements as the CPEP.

B. PVC Pipe and Fittings

Solid wall PVC storm sewer pipe and fittings shall comply with ASTM D3034, SDR 35 for pipe sizes up to 15 inches. Solid wall PVC storm sewer pipe and fittings shall comply with ASTM F 679 using a minimum pipe stiffness of 46 psi in accordance with Table 1 for pipe sizes from 18 inches to 48 inches. Pipe and fittings shall be furnished with bells and spigots, which are integral with the pipe wall and with a rubber gasket securely locked in place in the bell. Pipe joints shall conform to ASTM D3212 using flexible elastomeric gaskets conforming to ASTM F477.

C. Flexible Couplings

Flexible couplings shall be Calder-type where specifically indicated on the Plans. Calder-type flexible couplings shall consist of all elastomeric PVC sleeves secured to the pipes with stainless steel clamping bands. Adapter couplings shall be furnished for transitions between piping of different outside diameters as necessary.

Calder-type flexible couplings shall be as manufactured by Calder Co., Fernco, or equal.

SD-2 CATCH BASINS

Precast components shall conform to the requirements of ASTM C478. All Portland cement used in the manufacture of the precast sections shall conform to the requirements of ASTM C150 and shall be Type II or Type V.

Thickness of a Type 1 catch basin shall be 4 inches minimum and reinforced with welded wire fabric having a minimum area of 0.12 square inches per foot. Welded wire fabric shall comply with ASTM A497. "Knockouts" shall be free of welded wire fabric and provided on four sides to accommodate the pipe size, invert elevations, and direction as shown on the Plans.

Standard precast riser sections shall consist of rectangular sections to accommodate a Type 1 catch basin. Reinforcement shall be in accordance with ASTM C497. The minimum height of a riser section shall be 6 inches. The height of the riser and base sections shall be arranged so no pipes pass through the joining surfaces.

Precast base sections for Type 2 catch basins shall conform to the requirements for precast riser sections. The base shall be a minimum of 6 inches thick underneath the pipe invert.

Standard precast riser sections shall consist of circular sections in standard nominal inside diameter as shown on the Plans. Reinforcement shall be in accordance with ASTM C478. The minimum height of a riser section shall be 1 foot. The height of the riser and base sections shall be arranged so no pipes pass through the joining surfaces.

Openings for pipe shall be circular, tapered toward the inside of the section, and shall be of the minimum size possible to accommodate the size of pipe to be inserted and to effectively seal the joint.

Catch basin installation shall be as shown on the Plans. Precast sections with damaged joint surfaces or with cracks or damage that would permit infiltration shall not be installed.

Precast base sections shall be set on a prepared bedding material. Before the precast base is set, the gravel shall be carefully leveled to provide full bearing for the entire base slab.

The frame shall be set carefully to the established surface grade in a full bed of cement grout. The catch basin rim elevation shall be set flush with the pavement or improved areas.

SD-3 PRECAST CONCRETE DRY WELLS

The use of dry wells or infiltration facilities shall only be permitted when the requirements of the Washington State Department of Ecology Eastern Washington Stormwater Management Manual (current edition) have been met. When used, the developer's engineer shall provide full stormwater calculations to verify.

Precast components shall conform to the requirements of ASTM C478. All Portland cement used in the manufacture of the precast sections shall conform to the requirements of ASTM C150 and shall be Type II or Type V.

Precast base sections shall conform to the requirements for precast riser sections. The base shall be a minimum of 6 inches thick underneath the pipe invert. Openings for pipe shall be circular, tapered toward the inside of the section, and shall be of the minimum size possible to accommodate the size of pipe to be inserted and to effectively seal the joint.

Standard precast riser sections shall consist of circular sections in standard nominal inside diameter as shown on the Plans. Reinforcement shall be in accordance with ASTM C478. Minimum height of a riser section shall be 1 foot. The height of riser and base sections shall be arranged so no pipes pass through the joining surfaces.

The taper section (cone) shall be eccentric, tapering to 24-inches inside diameter, and shall be between 24-inches and 36-inches high.

Grade rings above the taper section shall be 24-inches inside diameter and 4-inches high. Grade ring height shall be a minimum of 8 inches, with a maximum of 20 inches. Otherwise, another section of manhole rings shall be installed.

Seepage port size and shape may vary per manufacturer. Each seepage port shall provide a minimum of 1 square inch and a maximum of 7 square inches for round openings and 15 square inches for rectangular openings. The ports shall be uniformly spaced with at least one port per 8 inches of drywell height and 15 inches per drywell circumference.

The dry well shall be surrounded by a geo-fabric lining meeting the requirements of "moderate survivability" geotextile for underground drainage strength properties for survivability (WSDOT Standard Specifications 9-33.2(2) Table 1) and gravel backfill per WSDOT Standard Specifications 9-03.12(5). A settling catch basin shall be installed upstream of the drywell to settle out solids prior to entering the dry well. All structures shall be cleaned before final acceptance.

SD-4 RINGS AND COVERS

Castings for manhole rings shall be gray-iron conforming to the requirements of ASTM A48/AASHTO M105, Grade 30B. Covers shall be ductile iron conforming to ASTM A536, Grade 80-55-06. All rings and covers shall be of uniform quality, free from blowholes, porosity, shrinkage, distortion, cracks, or other defects. Repair of defects shall not be permitted. All mating surfaces shall be machined finished to ensure a non-rocking fit. All covers shall be interchangeable within

the dimensions as shown on the Plans and marked "sewer," "drain," or "water" as appropriate. Locking/tamperproof covers shall be secured to the ring with three 5/8-inch stainless steel Allen head cap screws. When watertight covers are required the locking style ring and covers shall be used and include a machined groove in the seat of the ring or underside of the cover and a gasket installed to assure a watertight seal. Covers shall be without pickholes. The manufacturer's identification shall be cast with a minimum of 1/2-inch letters on exposed surfaces. Manhole rings and covers shall have a design wheel load conforming to AASHTO/ASTM A16 design loading HS20-44.

The frames and covers shall be made by Olympic Foundry, Inc., D&L Foundry, East Jordan Iron Works, or Neenah.

SD-5 STEPS

Polypropylene manhole steps shall be made of a copolymer polypropylene, superior in its resistance to corrosion, meeting the requirements of ASTM 2146 Type II, Grade 16906, and shall completely encapsulate a deformed 1/2-inch steel reinforcing rod conforming to ASTM A615, Grade 60. Polypropylene steps shall be factory-installed in complete accordance with the manufacturer's instructions. This shall be accomplished by predrilling two parallel 1-inch holes, 3-3/4-inch deep, and 13 inches on center in the cured concrete base, riser, and taper sections of the manhole. The insertion ends of the step shall be fully coated with non-shrink epoxy grout and then driven into the holes to the prescribed depth. In no case will the predrilled hole be allowed to penetrate through the wall of the manhole section.

Steps shall be Lane International Corporation Manhole Step or equal.

SD-6 FRAMES AND GRATES

Castings for catch basin and inlet frames shall be gray-iron conforming to the requirements of ASTM A48/AASHTO M105, Grade 30B. Grates or solid covers shall be ductile iron conforming to ASTM A536, Grade 80-55-06. All frames and grates or covers shall be of uniform quality, free from blowholes, porosity, shrinkage, distortion, cracks, or other defects. Repair of defects shall not be permitted. All mating surfaces shall be seated properly to prevent rocking of the grate/cover. The frames, grates, and covers shall have a design wheel load conforming to AASHTO/ASTM A16 design loading HS20-44.

The frames and grates/covers shall be made by East Jordan Iron Works, Olympic Foundry, Inc., D&L Foundry, or Neenah.

SD-7 BEEHIVE FRAME

The beehive frame shall be standard galvanized steel constructed from 3/4-inch smooth round bars and 3/4-inch- by 4-inch-wide bands. The upper opening shall be 2 feet in diameter and the vertical bars shall be at 45-degree angles. The use of beehive frames requires approval by the City prior to installation.

SD-8 GASKETS AND MANHOLE ADAPTERS

Rubber gaskets shall conform to Section 9-04.4 of the WSDOT Standard Specifications. Pipe connections to existing manholes shall be made using a heavy-duty sand collar with gasket, head, or equal. Pipe connections to new manholes or vaults shall utilize an adaptor coupling with gasket or watertight flexible rubber boot, Kor-n-Seal, or equal. The Contractor shall provide Kor-n-Seal cavity O-rings to fill the annular spaces between the pipe and the manhole or vault wall.

SD-9 INFILTRATION TRENCH

Infiltration trench will be shall be installed at the approval of the City. Geotechnical evidence of infiltration capacity is required for use of infiltration trenches. The infiltration trench shall be registered as an underground injection well with the Department of Ecology. The pipe used shall be perforated CPEP. The pipe shall be surrounded with a clean drain rock and the trench shall be wrapped with non-woven geotextile per the standard detail. The trench shall include a cleanout per the standard detail.

SD-10 TELEVISED INSPECTION

The Developer shall perform a complete televised inspection of the storm pipe and appurtenances and shall provide to the City a DVD or USB flash drive containing the inspections together with a written log of the inspections in a format that is accessible and approved by the City. The camera shall be a pan and tilt type equipped with adequate light and focusing to allow inspection of storm main and full circumference inspection of main line joints and fittings. The City shall determine if the quality of the tape is acceptable.

The City shall be notified 48 hours prior to any television inspection and this work shall be performed on a schedule to allow the City to witness the inspection.

If the television inspection shows indications of deflections in the pipe, the City may require that the Developer pull a proper sized mandrel for the main through the pipe to confirm that the pipe deflection does not exceed the manufacturer's recommendations.

Any defects in material or installation identified by the television inspection shall be repaired as required by the City at the Developer's expense. Should repairs be necessary, cutting of new paved areas will not be permitted without complete replacement of the wearing course of the paved area.

END CHAPTER 3

CHAPTER 4

SEWER

S-1 SEWER MAINS, LATERALS AND FORCE MAINS

Sewer pipe shall be polyvinyl chloride (PVC) for all sizes unless specifically noted otherwise.

Sewer mains to be installed shall be of the material noted below:

Gravity Sewer and Laterals:

PVC Pipe: up to 18' Cover

DI Pipe: 18' and Over
Slopes of 18 percent or greater with approval of the City

Force Main: DI Pipe

All types of pipe shall be handled in a manner that will prevent damage to the pipe, pipe lining, or coating. Pipe and fittings shall be loaded and unloaded using hoists and slings in a manner to avoid shock or damage, and under no circumstances shall they be dropped, skidded, or rolled against other pipes. Damaged pipe will be rejected, and the Developer shall immediately place all damaged pipe apart from the undamaged and shall remove the damaged pipe from the site within 24 hours.

Dirt or other foreign material shall be prevented from entering the pipe or pipe joint during handling or laying operations, and any pipe or fitting that has been installed with dirt or foreign material in it shall be removed, cleaned, and relayed. A clean whiskbroom shall be used for this purpose and for brushing to remove foreign matter prior to joining pipe ends. At times when pipe laying is not in progress, the open ends of the pipe shall be closed by a watertight plug or by other means approved by the City to ensure cleanliness inside the pipe.

Pipe shall be stacked in such a manner as to prevent damage to the pipe, to prevent dirt and debris from entering the pipe, and to prevent any movement of the pipe. The bottom tiers of the stack shall be kept off the ground on timbers, rails, or other similar supports. Pipe on succeeding tiers shall be alternated by bell and plain end. Timbers 4 inch by 4 inch in size shall be placed between tiers and chocks shall be placed at each end to prevent movement. For safety, each size of pipe shall be stacked separately.

Immediately upon beginning pipe installation, the Contractor shall place and secure a watertight plug in the sewer manhole. The plug shall remain in place throughout the project until such time as the project is accepted by the City. Failure to place the plug or removal of a plug prior to approval shall be grounds for City issued penalties.

A. PVC Pipe and Fittings

The PVC pipe shall be a minimum Class S.D.R. 35 and be manufactured in accordance with ASTM D3034. The pipe and fittings shall be furnished with bells and spigots, which are integral with the pipe wall. Pipe joints shall use flexible elastomeric gaskets conforming to ASTM D3212. Nominal laying lengths shall be 13 feet.

Tees for side sewer laterals shall be 6-inch-diameter fabricated tees. No field cut-in tees will be allowed without approval of the City.

If approved by the City, the connection shall be made by machine-made tap and Romac Style Sewer "CB" Saddle or Inserta Tee, available from Fowler Manufacturing Company or equal.

The gravity sewer pipe, unless otherwise approved by the City shall be laid upgrade from the point of connection on the existing sewer or from a designated starting point. The sewer pipe shall be installed with the bell end forward or upgrade. When pipe laying is not in progress, the forward end of the pipe shall be kept tightly closed with an approved temporary plug. Wherever movable shoring (steel box) is used in the ditch, pipe shall be restrained by the use of a winch mounted in the downstream manhole and a line of sufficient strength threaded through the pipe and set tight before each move. Any indication that joints are not being held shall be sufficient reason for the City to require restraints, whether or not movable shoring is being used.

All gravity sewer pipe shall be laid in straight lines and at a uniform rate of grade between manholes. Variance from established line and grade shall not be greater than 1/2 inch, provided that such variation does not result in a level or reverse sloping invert; provided, also, that variation in the invert elevation between adjoining ends of pipe, due to non-concentricity of joining surface and pipe interior surfaces, does not exceed 1/64 inch per inch of pipe diameter, or a total of 1/2 inch maximum. Any corrections required in line and grade shall be reviewed with the City and the repairs shall be made at the expense of the Developer.

Pipe handling after the gasket has been affixed shall be carefully controlled to avoid disturbing the gasket and knocking it out of position, or fouling the gasket with dirt or other foreign material. Any gaskets so disturbed shall be removed, cleaned, relubricated if required, and replaced before the rejoining is attempted.

Care shall be taken to properly align the pipe before joints are forced entirely home. During insertion of the tongue or spigot, the pipe shall be partially supported by hand, sling, or crane to minimize unequal lateral pressure on the gasket and thereby maintain concentricity until the gasket is properly positioned. Since most flexible gasketed joints tend to creep apart when the end pipe is deflected and straightened, such movement shall be held to a minimum once the joint is home.

Sufficient pressure shall be applied in making the joint to ensure that it is home, as described in the installation instructions provided by the pipe manufacturer. Sufficient restraint shall be applied to the line to ensure that joints once home are held so until fill material under and alongside the pipe has been sufficiently compacted. At the end of the workday, the last pipe laid shall be blocked in an effective way to prevent creep during "down time."

All gravity sewer pipe shall be bedded with gravel as shown on the details. The pipe shall be bedded from a depth of 4 inches below the pipe to 12 inches above the pipe. The bedding material shall extend across the full width of the trench and shall be compacted under the haunches of the pipe.

Special concrete bedding when required to provide additional support for the pipe shall consist of a pipe cradle constructed of Portland cement concrete containing not less than four sacks of cement per cubic yard. Sand, gravel, and water proportions are subject to approval by the City. Maximum aggregate size shall be one and 1-1/2 inches. Maximum slump shall be 4 inches. The bottom of the trench shall be fully compacted before the placement of the pipe cradle. The Developer shall protect the pipe against flotation and disturbing the horizontal alignment of the pipe during the pouring of the concrete.

Clay or bentonite dams shall be installed across the trench, keyed into native undisturbed soil and to the full depth of the granular material in all areas of steep slopes, stream crossings, and within wetlands to prevent migration of water along the pipeline. The City shall determine where trench dams are required.

B. Ductile Iron Pipe and Fittings

DI pipe may be used, under special circumstances only, with the approval of the City. The ductile iron pipe shall conform to AWWA C151 Standards, except the minimum nominal thickness shall be as follows:

- 6" - 0.25" (Class 52)
- 8" - 0.27" (Class 52)
- 10" - 0.29" (Class 52)
- 12" - 0.31" (Class 52)

Grade of iron shall be 60-42-10. The pipe shall be polyethylene or epoxy lined to a nominal thickness of 40 mils. Minimum lining thickness shall be 30 mils. The exterior shall be coated with an asphaltic coating. Products meeting the standard are US pipe "Polylined," "Protecto 401" and American Pipe "Polyband" or approved equal.

Each length shall be plainly marked with the manufacturer's identification, year cast, thickness, class of pipe, and weight. The pipe shall be furnished with mechanical joint or push-on joint, conforming to AWWA C111 Standards, except where otherwise noted calling for flanged joints.

Restrained joint pipe, where shown on the Plans, shall be push-on joint pipe with "Field Lok" gaskets or TR FLEX as furnished by US Pipe or approved equal.

The pipe manufacturer shall certify in writing that the inspection and all tests of the specified standards for both pipe and gaskets being supplied for this project have been made and that the results thereof comply with the requirements of the Standard.

Joints shall be "made up" in accordance with the manufacturer's recommendations. Standard joint material, including rubber ring gaskets, shall be furnished with the pipe. Materials shall be suitable for the specified pipe sizes and pressures. The pipe joint utilized shall be the patented "Tyton" joint.

All fittings shall be short-bodied, ductile iron complying with applicable AWWA C110 or C153 Standards. All fittings shall be polyethylene or epoxy lined and either mechanical joint or flanged, as indicated on the Plans.

Fittings in sections shown on the Plans requiring restrained joints shall be mechanical joint fittings with a mechanical joint restraint device. The mechanical joint restraint device shall have a working pressure of at least 250 psi with a minimum safety factor of 2:1 and shall be EBAA Iron, Inc., MEGALUG, Romac Industries, Inc., Grip Ring Pipe Restrainer, or approved equal. Stargrip Series 3000 mechanical joint restraint devices are not accepted or approved as equal.

Fittings shall be adequately "blocked" with poured-in-place concrete, within wooden forms shaped to establish a firm minimum bearing area, against an undisturbed earth wall as shown on the Standard Details. Timber blocking will not be permitted. The concrete thrust blocks must be in place at least 24 hours before beginning the pressure test, to allow the concrete to "set." The strength of the concrete shall be 2,000 psi minimum.

All fittings requiring a concrete block shall first be covered with 20-pound tarpaper before concrete is poured. The concrete shall not cover joints, bolt heads, or nuts.

All bolts shall be coated with Armitite Anti-Seize Compound No. 609, or equal, prior to installation.

All connections to ductile or cast iron pipe shall be with ductile iron mechanical joint sleeves except as shown on the Plans for mechanical joint tees, valves, etc.

D. Side Sewer Laterals

A side sewer lateral is considered to be that portion of a sewer line that will be constructed between a main sewer line and a property line or easement limit line.

All applicable specifications given herein for sewer construction shall be held to apply to side sewer laterals. The side sewer lateral shall be of the same material as the mainline, except as noted in the Standing Side Sewer Detail.

Side sewers shall be for a single service connection only and be a minimum 6-inch-diameter pipe. Side sewers shall be connected to the tee, provided in the sewer main where such is available, utilizing approved fittings or adapters. The side sewer shall rise at a maximum of 45 degrees and a minimum of 2 percent, extending from the sewer main.

The maximum bend permissible at any one fitting shall not exceed 45 degrees. Any bend, or combination of bends equaling 45 degrees shall consist of or be followed by a wye cleanout.

Where there are no basements, the minimum side sewer depth shall be 6 feet below the existing curb line and 5 feet below ground at the property line, except where existing improvements, proposed improvements or topography may dictate additional depth. The elevations of the side sewer connections shall be of sufficient depth to serve all existing and potential future basements.

Sewer Grinder Pumps are not allowed except by special approval from the City. Where standard conforming gravity service cannot be achieved and denial of service is the only remaining option, private ownership of grinder pumps may be considered by the City. The Developer's Engineer shall provide the City with information utilized in determining gravity service unavailability showing that all means of achieving gravity service, regardless of cost, have been reviewed and eliminated. If it is proven that gravity service is unavailable, only then will the City accept the Developers Engineer's proposal identifying pump design and the areas to be served for City review and approval.

E. Grease Interceptors

Grease interceptors shall be provided for all Commercial, Industrial, or School food establishments and when specified by the City. The interceptor shall be installed as close as possible to the source of grease/fat. When specified by the City, a Sample Chamber shall be installed immediately downstream of the Grease Interceptor.

S-2 MANHOLES

Manholes shall be of the offset type and shall be precast concrete sections with either a cast-in-place base, or a precast base made from a minimum 3,000 psi structural concrete. Joints between precast wall sections shall be confined O-ring or as otherwise specified. All manholes over 20 feet in depth shall be a minimum of 54 inches in diameter.

For connections to existing manholes, a concrete coring machine, suitable for this type of work, shall be utilized in making the connection. The existing manhole shall be rechanneled as required. The new pipe connection shall be plugged (watertight) until the new pipe system has been installed and approved. The Developer shall be responsible for any existing defects in the existing manhole unless these defects are witnessed by the City prior to any work being performed to make the connection. The Developer shall be required to remove any and all deleterious material in the existing manhole and downstream reaches as a result of their connection.

The Developer shall excavate completely around the manhole to prevent unbalanced loading. The manhole shall be kept in operation at all times and the necessary precautions shall be taken to prevent debris or other material from entering the sewer.

A. Manhole Sections

Manhole sections shall be placed and aligned so as to provide vertical sides and vertical alignment of the ladder steps. The completed manhole shall be rigid, true to dimension, and watertight. Rough, uneven surfaces will not be permitted.

B. Manhole Steps

Manhole steps shall be polypropylene, MA Industries, 1/2-inch Grade 60 steel, PS2-PF or equal.

C. Grade Adjustment

Each manhole shall be provided with not less than 14 inches or more than 18 inches of grade adjustment between the top of the cone and the top of the manhole frame.

Masonry units or precast concrete adjustment rings shall be installed to adjust to final grade. The outside and inside of manhole adjusting bricks or rings and the joints of precast concrete sections shall be plastered and troweled smooth with 1/2 inch (minimum) of mortar in order to attain a watertight surface.

In unpaved areas, a 4-foot-diameter by 8-inch-thick concrete collar shall be poured around the manhole with a manhole marker post unless prior authorization has been granted by the City.

D. Channels

Channels shall be made to conform accurately to the sewer grade and shall be brought together smoothly with well-rounded junctions, satisfactory to the City. The channels shall be field poured after the inlet and outlet pipes have been laid and firmly grouted into place at the proper elevation. Allowances shall be made for a 0.1-foot drop in elevation across the manhole in the direction of flow. Channel sides shall be carried up vertically from the invert to three-quarters of the diameter of the various pipes. The concrete shelf shall be warped evenly and sloped 3/8 inch per foot to drain. Rough, uneven surfaces will not be permitted. Channels shall be constructed to allow the installation and use of a mechanical plug or flow meter of the appropriate size.

E. Pipe Connections

All pipe connections to the manhole shall be with grouting a Heavy Duty sand collar, Kor-N-Seal flexible connector, or equal into the manhole wall.

F. Lift Holes and Steel Loops

All lift holes shall be completely filled with expanding mortar, smoothed both inside and outside, to ensure water tightness. All steel loops shall be removed, and flush with the manhole wall. The stubs shall be covered with mortar and smoothed. Rough, uneven surfaces will not be permitted.

G. Frames and Covers

Frames and covers shall be ductile iron as shown on the standard detail. Castings shall be free of porosity, shrink cavities, cold shuts or cracks, or any surface defects, that would impair serviceability. Repair of defects by welding, or by the use of "smooth-on" or similar material, will not be permitted. Frames and covers shall be machine-finished or ground on seating surfaces to assure non-rocking fit in any position and interchangeability of covers.

Frames and covers shall be adjusted to conform to the final finished surface grade of the street or easement to the satisfaction of the City.

H. Manhole Fall Protection

All manholes that are 20 feet or over in-depth, measured from finished grade to invert of the pipe, shall be a minimum of 54 inches in diameter (or a size specified by the City) to facilitate the use of fall protection equipment.

S-3 TESTING GRAVITY SEWERS

The Developer shall furnish all facilities and personnel for conducting tests under the observation of the City. Methods other than low-pressure air tests shall be subject to the approval of the City.

A. Preparation for Testing for Leakage

Before any leakage test is performed, the Developer shall clean and flush all gravity sewer lines with an approved rodding method or with a cleaning ball and clean water prior to testing. The inflatable diagonally ribbed rubber ball shall be of a size that will inflate to fit snugly into the pipe to be tested. After completion of backfill and cleaning, the completed gravity sewer, including side sewer stubs, shall be televised inspected. This will be permitted prior to paving. If the television inspection reveals excess debris, the Developer shall clean and televise again at its own expense. The sewer shall then be tested by the low-pressure air test method but only after all utilities are installed and the project paved. Except, however, that in certain conditions an exfiltration test may be required by the City.

The first section of pipe, not less than 300 feet in length, installed by each crew shall be tested in order to qualify the crew and/or the material. A successful installation of this first section shall be a prerequisite for further pipe installation by the crew. At the Developer's option, crew and/or material qualification testing may be performed at any time during the construction process after at least 2 feet of backfill has been placed over the pipe.

All debris flushed out of the line shall be removed at the first manhole where its presence is noted. In the event cemented or wedged debris or a damaged pipe shall stop the cleaning operation, the Developer shall remove the obstruction, and/or repair any damaged pipe. All visible leaks showing flowing water in pipelines or manholes shall be stopped even if the test results fall within the allowable leakage. The cleaning shall be carried out in such a manner as to not infiltrate water into existing facilities. Precautions shall be taken to prevent any damage caused by cleaning and testing. Any damage resulting shall be repaired by the Developer at its own expense. The manner and time of testing shall be subject to the approval of the City.

B. Low Pressure Air Test

The sewer pipe shall be tested for leaks through the use of air in the following manner:

Immediately following the pipe cleaning and television inspection, the pipe installation shall be tested with low-pressure air. Air shall be slowly supplied to the plugged pipe installation until the internal air pressure reaches 4.0 pound per square inch greater than the average back pressure of any groundwater that may submerge the pipe. At least 2 minutes shall be allowed for temperature stabilization before proceeding further.

The rate of air loss shall then be determined by measuring the time interval required for the internal pressure to decrease from 3.5 to 2.5 pounds per square inch while maintaining the stipulated pressure greater than the pipe section's average adjacent groundwater back pressure.

The pipeline shall be considered acceptable if the total rate of air loss from any section tested in its entirety between manholes, cleanouts, or pipe ends meets the requirements of Section 7-04.3(1)E of the WSDOT Standard Specifications.

Test times will be provided by the City for combinations other than 8-inch mains and 6-inch laterals.

If the pipe installation fails to meet these requirements, the Developer shall determine at its own expense the source or sources of leakage and shall repair (if the extent and type of repairs proposed by the Developer appear reasonable to the City) or replace all defective materials or workmanship. The completed pipe installation shall meet the requirements of this low-pressure air test or the alternative water exfiltration test before being considered for acceptance.

Plugs used to close the sewer pipe for the air test shall be securely braced with non-buoyant material to prevent the unintentional release of a plug, which can become a high-velocity projectile. Gauges, air piping manifolds, and valves shall

be located at the top of the ground. No one shall be permitted to enter a manhole where a plugged pipe is under pressure. Air testing apparatus shall be equipped with a pressure release device such as a rupture disk or a pressure relief valve designed to relieve pressure on the pipe under test at 6 psi.

S-4 TESTING FORCE MAINS

The force mains shall be hydrostatically tested before being placed in service. Water for testing must be obtained by the Developer by arrangement with the City. A positive displacement type pump shall be furnished by the Developer for the testing. Feed for the pump shall be from a container, wherein the actual amount of "makeup" water can be measured.

The test pressure shall be either 200 pounds per square inch, or twice the system pressure, using the greater value and shall maintain the test for a period of not less than 1 hour. The test pressure shall be applied at the low end of the section tested.

The Developer shall provide temporary plugs, caps, and blocking as required to pressure test the new force main.

Concrete thrust blocking for fittings shall be in place and the concrete "set" sufficiently to withstand the test pressure before starting the test.

Prior to calling for the City to witness the pressure test, the Developer shall first perform a satisfactory pressure test. The allowable leakage rate per thousand feet of each size pipeline is as follows:

<u>Pipe Size</u>	<u>Allowable Leakage Gal. per Hour per 1,000 Ft. @ 200 psi</u>
6"	0.64
8"	0.85
10"	1.06
12"	1.28

Any leakage caused by defective workmanship or materials shall be repaired, and the line shall again be tested to full compliance.

S-5 TELEVISED INSPECTION

After manhole adjustment, installation of pavement, channeling and the gravity sewer lines have been cleaned and flushed, the Developer shall provide a complete televised inspection.

The Developer shall perform a complete televised inspection of the sewer pipe and appurtenances and shall provide to the City a DVD or USB of the inspections together with a written log of the television inspection. The camera shall be a pan and tilt type equipped with adequate light and focusing to allow inspection of sewer main, side sewers and full circumference inspection of main line joints and fittings. The City shall determine if the quality of the televised inspection is acceptable.

Immediately prior to the televised inspection, the Developer shall run water through each sewer line for 5 to 10 minutes to provide water for detection of any adverse grade sections visible by the presence of ponded water. The camera shall be stopped periodically at the ponded areas and the depth of water shall be measured with a ball of known diameter on the pull line. Ponding shall not be greater than 1/16 inch per inch of pipe diameter and not exceed 1/2 inch in depth. During the inspection, all tees and other fittings shall be logged as to the exact location within 1 percent maximum error in measurement, wherein accuracy is checked with various fittings and the terminating manhole.

The City shall be notified 48 hours prior to any television inspection and this work shall be performed on a schedule to allow the City to witness the inspection.

If the television inspection shows indications of deflections in the pipe, the City may require that the Developer pull a proper sized mandrel for the main through the pipe to confirm that the pipe deflection does not exceed the manufacturer's recommendations.

Any defects in material or installation identified by the television inspection shall be repaired as required by the City at the Developer's expense.

S-6 COLLECTION SYSTEM PUMP STATIONS

Sewage Lift Stations shall be designed in accordance with the current edition of Criteria for Sewage Works Design by the Washington State Department of Ecology. Sewage Lift Stations shall consist of a wet well with two submersible pumps (Flgyt or approved equal), each capable of meeting the design flow requirements. Telemetry and controls shall be provided in accordance with the City's most current standards. The Developer shall contact the City's designated system controls integrator for current standards. An alternate power supply (generator) shall be provided by the Developer.

END CHAPTER 4

CHAPTER 5

STREETS

ST-1 EXCAVATION AND SUBGRADE PREPARATION

Existing material shall be excavated and hauled from the project site as necessary to accommodate the proposed finished grade and roadway section. If the subgrade is disturbed during excavation, the subgrade shall be compacted prior to placing new roadway material.

Unsuitable subgrade materials, including but not limited to: unstable or soft soils such as peat, muck, and clay; roots, buried logs, buried stumps, garbage, or other debris shall be excavated and hauled from the project site. Unsuitable foundation excavation shall be replaced with Gravel Borrow. If needed to stabilize soft material, the excavation shall be lined with construction geotextile for separation before placing gravel borrow.

Construction Geotextile for Separation shall conform to the material requirements of Section 9-33 of the WSDOT Standard Specifications.

Gravel Base shall conform to the material requirements of Section 9-03.10 of the WSDOT Standard Specifications.

ST-2 ROADWAY CONSTRUCTION

New roadway construction (including full width construction, partial width construction, and patching) shall consist of a crushed surfacing and pavement as shown in the Details.

Roadway edges shall consist of a 6-foot-wide, 4-inch compacted depth Crushed Surfacing Top Course shoulder or cement concrete curb, gutter, and sidewalk. Roadway signs shall be placed in accordance with WSDOT Standard Plan G-20.10-02.

Pavement joints shall consist of neat line sawcut edge and shall receive a tack coat prior to paving. Apply asphalt paving sealant to joints.

Asphalt thickened edge and asphalt berms shall be constructed of Commercial HMA along a straight, neat line, and shall be graded to drain. If constructed after wearing course is in place, joints shall be sealed with paving asphalt.

Paved surfaces intended for use as pedestrian walkways shall be constructed in accordance with the requirements for slope, grade, dimensions, and surface smoothness, and other criteria set forth by the Americans with Disabilities Act (ADA) and detailed in the WSDOT Field "Guide for Accessible Public Rights of Way" and the United States Access Board "Proposed Accessibility Guidelines for Pedestrian Facilities in the Public Right-of-Way."

Crushed Surfacing Base Course shall conform to the construction and material requirements of Section 4-04 of the WSDOT Standard Specifications.

Commercial HMA shall conform to the construction and material requirements of Section 5-04 of the WSDOT Standard Specifications.

Bituminous Surface Treatment shall conform to the construction and material requirements of Section 5-02 of the WSDOT Standard Specifications.

ST-3 CONCRETE CURBS AND PEDESTRIAN FACILITIES

All pedestrian facilities shall be constructed in accordance with the requirements for slope, grade, dimensions, and surface smoothness, and other criteria set forth by the Americans with Disabilities Act (ADA) and detailed in the WSDOT “Field Guide for Accessible Public Rights of Way” and the United States Access Board “Proposed Accessibility Guidelines for Pedestrian Facilities in the Public Right-of-Way”

Cement Concrete Curb and Gutter, Cement Concrete Pedestrian Curbs, and other curbs including extruded curb shall conform to the construction and material requirements of Section 8-04 of the WSDOT Standard Specifications.

Cement Concrete Driveway Entrances shall conform to the construction and material requirements of Section 8-06 of the WSDOT Standard Specifications.

Cement Concrete Sidewalks and Cement Concrete Curb Ramps shall conform to the construction and material requirements of Section 8-14 of the WSDOT Standard Specifications.

ST-4 STREET CLASSIFICATIONS

The classifications of all streets shall be established by the Public Works Department. Street changes in classifications shall be shown to meet the following criteria. Refer to the Standard Details at the end of this section.

LOCAL ACCESS STREET: A short street, cul-de-sac, court or a street with branching places or lanes. A Local Access Street is a minor residential street, and usually there is not through traffic between two streets of a higher classification. The ADT (Average Daily Traffic) can reach up to 1500. Local access streets are only allowed upon approval from the Public Works Department. Face of curb radii shall be to the lowest street classification of the intersection and shall be a minimum 25' radius on Local Access Streets. Street centerline radii shall be designed to a minimum 30 mph design speed or as approved by the City. Sidewalks shall be required on Local Access streets where designated by the City.

COLLECTOR: The Collector is a secondary street in the urban system and correspondingly has the second highest average daily traffic (ADT). The Collector generally receives many vehicles from Local Streets and/or is the major route to significant activity centers. Collector streets should not generally be encumbered with stop signs. The ADT (Average Daily Traffic) can exceed 1,500+. Face of curb radii shall be to the lowest street classification of the intersection and shall be a minimum 25' radius on Collector Streets. Street centerline radii shall be designed to a minimum 35 mph design speed or as approved. Collectors shall be further defined by the location and types of generators served. Collectors serving primarily commercial or industrial areas shall be classified as Major Collectors. Collectors serving primarily residential areas shall be classified as Minor Collectors.

ARTERIAL: Arterial streets contain the greatest proportion of through travel. Such facilities serve the high-volume travel corridors that connect the major generators of traffic. Arterials typically connect with collectors that extend into the urban area. Face of curb radii shall be to the lowest street classification of the intersection and shall be a minimum 30' radius on Arterial Streets. Street centerline radii shall be designed to a minimum 25 mph design speed or as approved by the City. Arterials shall be further defined by the location and types of generators served. Arterials serving primarily commercial or industrial areas shall be classified as Principal Arterials. Arterials serving primarily residential areas shall be classified as Minor Arterials.

* In extreme situations, with consent of the City and with possible parking restrictions as determined by the City, the width of roadway may be reduced. This reduction may only take place in situations where major utilities or streams, etc., are in conflict with improvements. Sidewalks and other roadway features may be required to be located at a location suitable for ultimate buildout.

** Centerline striping will be performed for Arterial and major Collector streets only (See street classification map) and as required by the MUTCD Manual.

ST-5 STREET LIGHTING

Poles, luminaires, and installation shall comply with local electrical utility requirements and shall be coordinated with the City. Lighting levels shall conform to WSDOT Design Manual guidelines. Pole design and luminaire selection shall meet the following standards:

Part	Criteria
Pole	
Model	Valmont Model No. 270845808T4 Aluminum Alloy, 100 Grit Satin Polish, or equal
Pole Height	30 feet
Mast Arm Length	6 feet
Color	Gray
Base Type	Slip Base
Luminaire	
Model	AEL Autobahn ATBM or equal
Type	LED
Lumens	12,800 lumens
Power	94 W
Color Temperature	4000k, 70 CRI minimum
Adjustable Output/Dimmable	Included
Light Trespass Shield	Included
Distribution Type	Type III
Voltage	240 V

END CHAPTER 5

STANDARD DETAILS



CITY OF ROSLYN CONSTRUCTION STANDARDS

**2024
G&O JOB #23867**





INDEX OF STANDARD DETAILS	
SHEET #	SHEET DESCRIPTION
	<u>WATER DETAILS</u>
W-1	WATER MAIN TRENCH SECTION
W-2	THRUST BLOCKS
W-3	VERTICAL ANCHOR BLOCK
W-4	TYPICAL VALVE INSTALLATION
W-5	VALVE STEM EXTENSION
W-6	VALVE MARKER
W-7	FIRE HYDRANT ASSEMBLY
W-8	3/4" OR 1" WATER SERVICE
W-9	1-1/2" OR 2" WATER SERVICE
W-10	BLOW OFF ASSEMBLY
W-11	1" AIR AND VACUUM RELEASE ASSEMBLY
W-12	TRENCH PATCH
W-13	ACCESS EASEMENT AND ROADWAY FOR MUNICIPAL UTILITIES
W-14	FIRE DEPARTMENT CONNECTION (FDC)
	<u>STORM DETAILS</u>
SD-1	STORM DRAIN TRENCH SECTION
SD-2	CATCH BASIN - TYPE 1
SD-3	CATCH BASIN - TYPE 1A
SD-4	CATCH BASIN - TYPE 2
SD-5	PRECAST CONCRETE DRYWELL
	<u>SEWER DETAILS</u>
SS-1	SANITARY SEWER TYPICAL TRENCH SECTION
SS-2	STANDARD 48" MANHOLE
SS-3	MANHOLE PLAN VIEW
SS-4	SADDLE MANHOLE
SS-5	SHALLOW MANHOLE
SS-6	DROP MANHOLE CONNECTION
SS-7	STANDARD MANHOLE FRAME AND COVER
SS-8	MANHOLE STEP
SS-9	CONNECTION TO EXISTING SANITARY SEWER MANHOLE
SS-10	STANDARD SIDE SEWER
SS-11	BUILDING SIDE SEWER CLEANOUT
SS-12	SANITARY SEWER CLEANOUT
SS-13	COLLECTION SYSTEM PUMP STATION
SS-14	COLLECTION SYSTEM PUMP STATION SECTION
SS-15	GREASE INTERCEPTOR
	<u>STREET DETAILS</u>
ST-1	TYPICAL ROADWAY SECTION
ST-2	TYPICAL CONCRETE SIDEWALK
ST-3	TYPICAL CURB AND GUTTER
ST-4	CONCRETE DRIVEWAY ENTRANCE OPTION A
ST-5	CONCRETE DRIVEWAY ENTRANCE OPTION B
ST-6	PARALLEL SIDEWALK RAMP
ST-7	PERPENDICULAR SIDEWALK RAMP
ST-8	SINGLE DIRECTION CURB RAMP
ST-9	TYPICAL UTILITY CROSSING
ST-10	TYPICAL ALLEY
ST-11	CUL-DE-SAC STANDARD
ST-12	MONUMENT CASE AND COVER
ST-13	ORNAMENTAL LIGHTING
ST-14	RETAINING WALL
ST-15	CONCRETE STAIR
ST-16	HANDRAIL

WATER DETAILS

SURFACE REPAIR REQUIREMENTS SHALL BE DETERMINED BY CITY

FINISHED GRADE

6" WIDE DETECTABLE MARKING TAPE

CRUSHED SURFACING TOP COURSE

SPECIAL PRECAUTIONS TO PROTECT PIPE TO THIS LEVEL

GRAVEL BACKFILL FOR PIPE BEDDING, CRUSHED SURFACING TOP COURSE OR APPROVED BEDDING MATERIAL

14 GAUGE TRACER WIRE, CONNECT BETWEEN VALVES TAPE TO TOP OF PIPE

PVC WATER PIPE

FOUNDATION GRAVEL AS REQUIRED

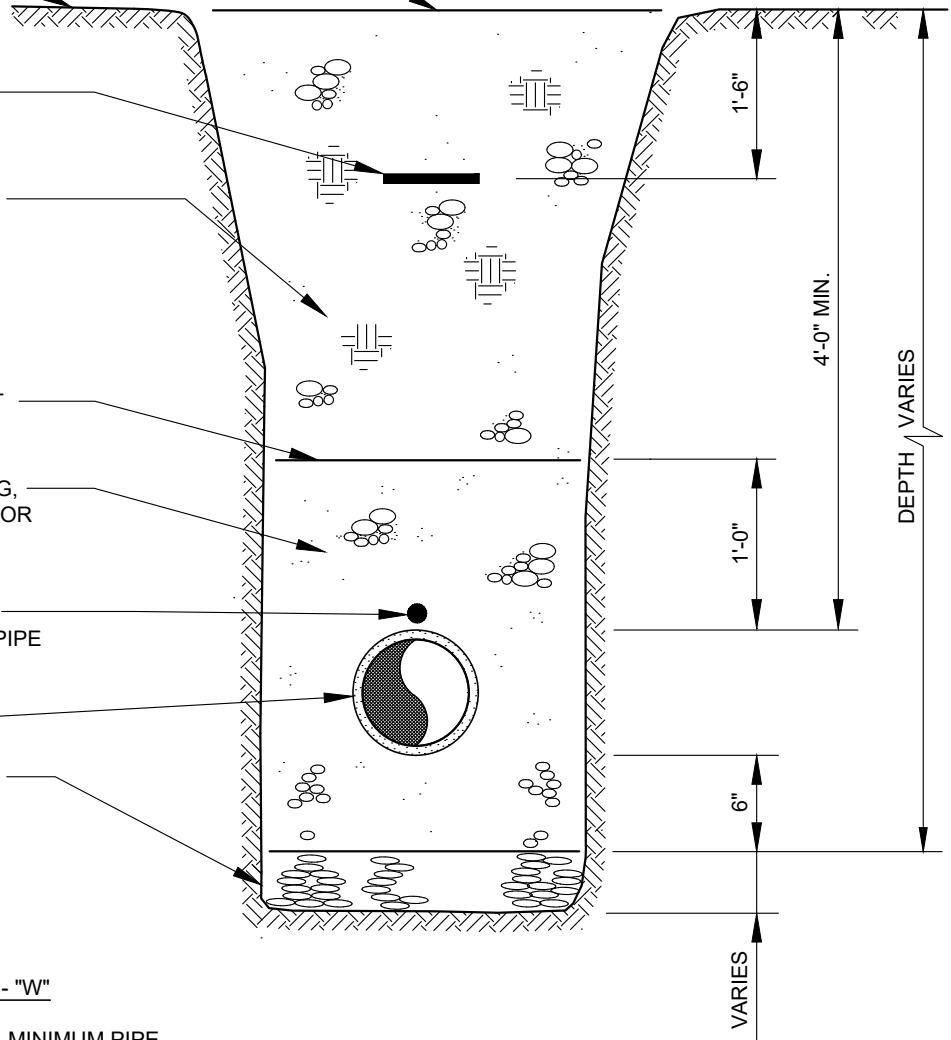

MINIMUM TRENCH WIDTH - "W"

	MINIMUM PIPE COVER "L"	MINIMUM PIPE DIAMETER "D"
WATER MAINS	48 INCHES	8 INCH
WATER SERVICES	30 INCHES	1 INCH

NOTE:

MINIMUM TRENCH WIDTH FOR MAINS IS PIPE SIZE PLUS 18 INCHES. ALL TRENCHES SHALL MEET WAC CHAPTER 298-155 FOR CONSTRUCTION WORK.

M:\ROS\YN\23867 Construction Standards Update\Figures\WATER\W-1.dwg, 10/1/2024 10:40 AM, FRANK PARKER



CITY OF ROSLYN
 CONSTRUCTION STANDARDS
DETAIL W-1
WATER MAIN TRENCH SECTION



Gray & Osborne, Inc.
 CONSULTING ENGINEERS

MINIMUM BEARING AREA TABLE

FITTING D	TEE	90°	45°	22 1/2°	11 1/4°
6"	4 SQ FT	6 SQ FT	3 SQ FT	2 SQ FT	2 SQ FT
8"	7 SQ FT	10 SQ FT	6 SQ FT	3 SQ FT	2 SQ FT
10"	10 SQ FT	15 SQ FT	9 SQ FT	5 SQ FT	3 SQ FT
12"	14 SQ FT	22 SQ FT	12 SQ FT	6 SQ FT	4 SQ FT
16"	25 SQ FT	38 SQ FT	21 SQ FT	11 SQ FT	7 SQ FT
18"	32 SQ FT	48 SQ FT	27 SQ FT	14 SQ FT	8 SQ FT

TYPICAL FOR SANDY SOIL WITH 2,000 PSF BEARING STRENGTH & 100 PSI WORKING PRESSURE. ADJUST BEARING AREA BY PRESSURE & SOIL BEARING CAPACITY. USE TEE FOR DEAD ENDS.

NOTES

1. BLOCKING SHALL BE TO SOLID BEARING SURFACE.
2. FITTING SHALL BE PROTECTED WITH VISQUEEN.
3. BEARING AREA SHALL BE PROPORTIONALLY INCREASED WITH PRESSURES IN EXCESS OF 100 PSI OR IN SOIL CONDITIONS WITH LESS THAN 2,000 PSF BEARING STRENGTH.
4. ALL BLOCKS ON TEES SHALL BE SEPARATED FOR DIRECTION OF THRUST.

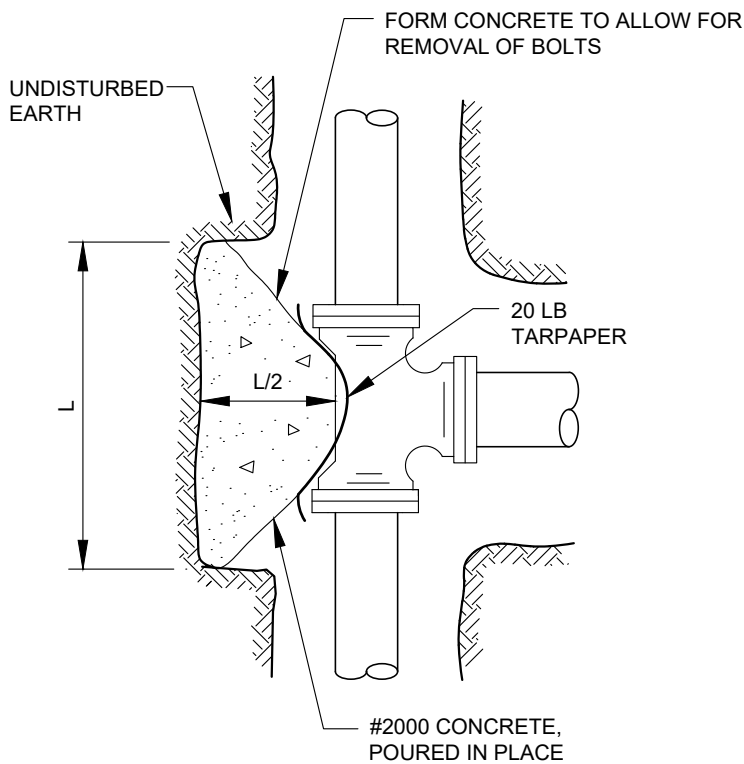

PLAN

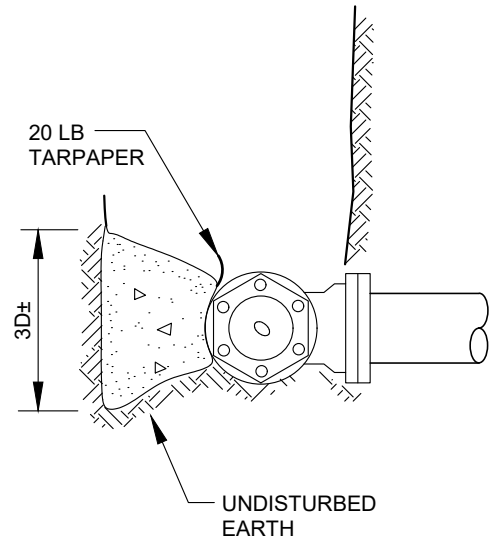

ELEVATION

M:\ROS\YN\23867 Construction Standards Update\Figures\WATER\W-2.dwg, 10/1/2024, 10:40 AM, FRANK PARKER



CITY OF ROSLYN

CONSTRUCTION STANDARDS

DETAIL W-2

THRUST BLOCKS



Gray & Osborne, Inc.
CONSULTING ENGINEERS

TYPE "A" BLOCKING
FOR 11 1/4° - 22 1/2° - 30° VERTICAL BENDS

		VB		S	D	L
PIPE SIZE NOMINAL DIAMETER- INCHES	TEST PRESSURE PSI	VERTICAL BEND DEGREES	No. OF CU. FT. OF CONC. BLOCKING	SIDE OF CUBE LIN. FT.	DIAM. OF SHACKLE RODS (2) INCHES	DEPTH OF RODS IN CONCRETE LIN. FT.
4"	300	11 1/4	8	2	5/8"	1.5
		22 1/2	11	2.2		2.0
		30	17	2.6		
6"	300	11 1/4	11	2.2	5/8"	2.0
		22 1/2	25	2.9		
		30	41	3.5		
8"	300	11 1/4	16	2.5	5/8"	2.0
		22 1/2	47	3.6		
		30	70	4.1	3/4"	2.5
12"	250	11 1/4	32	3.2	5/8"	2.0
		22 1/2	88	4.5	7/8"	3.0
		30	132	5.1		
16"	225	11 1/4	70	4.1	7/8"	3.0
		22 1/2	184	5.7	1 1/8"	4.0
		30	275	6.5	1 1/4"	
20"	200	11 1/4	91	4.5	7/8"	3.0
		22 1/2	225	6.1	1 1/4"	4.0
		30	330	6.9	1 3/8"	4.5
24"	200	11 1/4	128	5.0	1"	3.5
		22 1/2	320	6.8	1 3/8"	4.5
		30	480	7.9	1 7/8"	5.5

TYPE "B" BLOCKING
FOR 45° VERTICAL BENDS

		VB		S	D	L
PIPE SIZE NOMINAL DIAMETER- INCHES	TEST PRESSURE PSI	VERTICAL BEND DEGREES	No. OF CU. FT. OF CONC. BLOCKING	SIDE OF CUBE LIN. FT.	DIAM. OF SHACKLE RODS (2) INCHES	DEPTH OF RODS IN CONCRETE LIN. FT.
4"	300	45	30	3.1	5/8"	2.0
6"			68	4.1		
8"			123	5.0		
12"	250		232	6.1	3/4"	2.5
16"	225		478	7.8	1 1/8"	4.0
20"	200		560	8.2	1 1/4"	
24"			820	9.4	1 3/8"	4.5

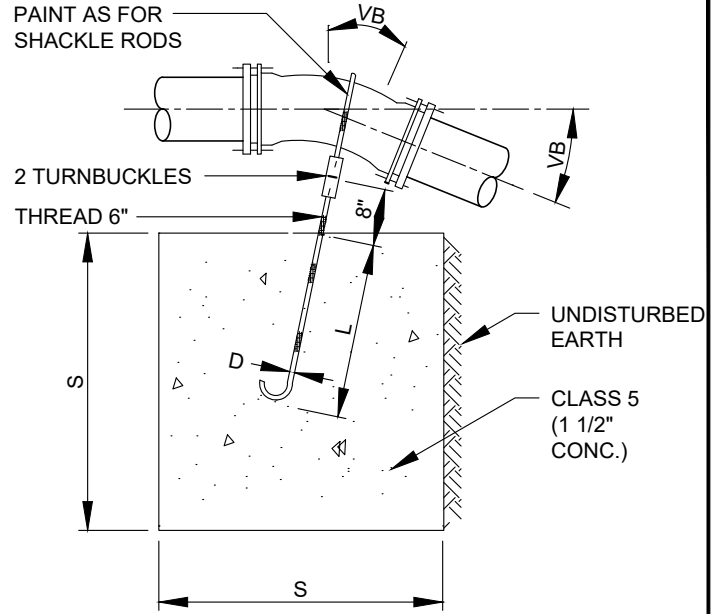

TYPE "A" BLOCKING

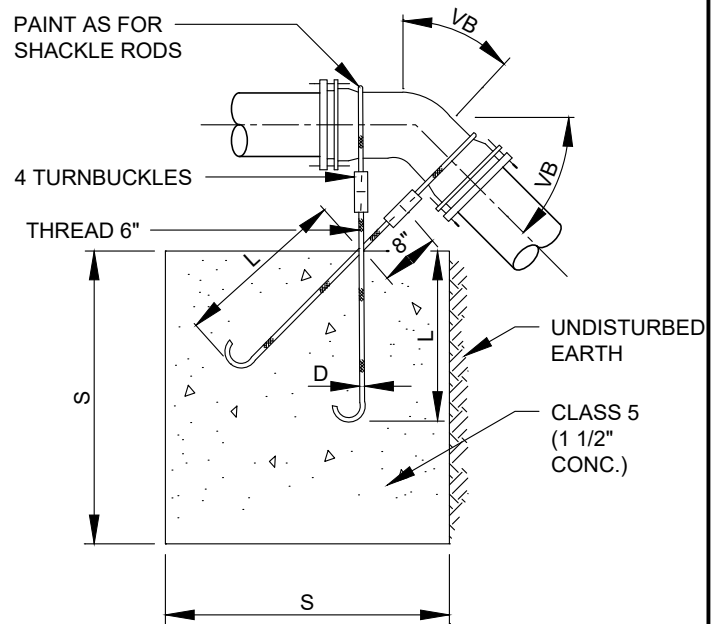

TYPE "B" BLOCKING

CITY OF ROSLYN
 CONSTRUCTION STANDARDS
DETAIL W-3
VERTICAL ANCHOR BLOCK



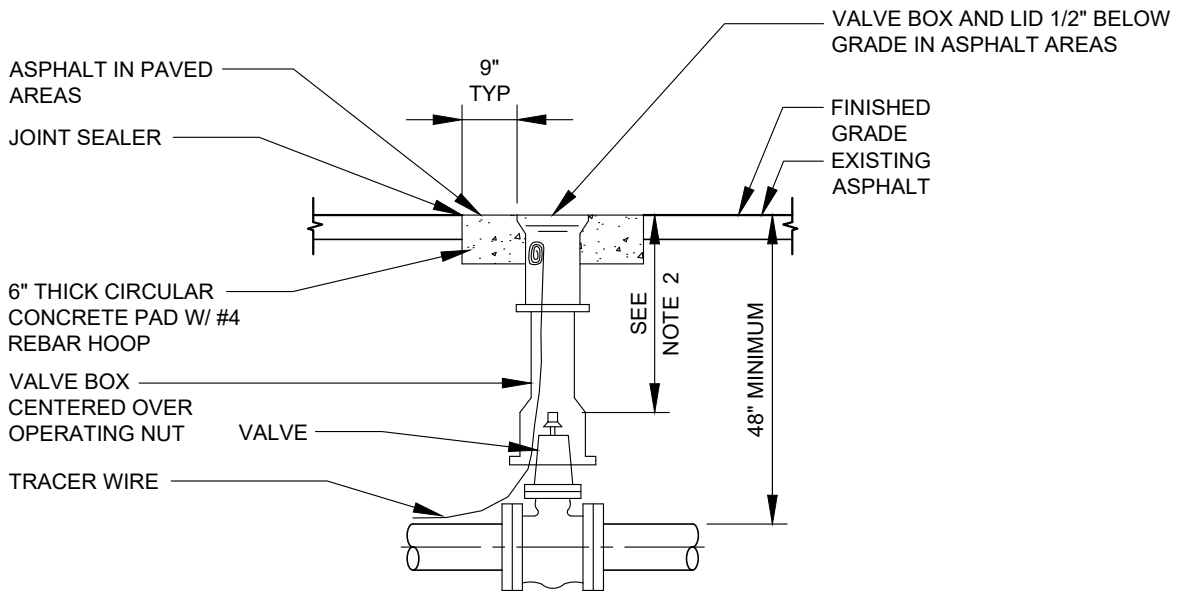

VALVE BOX IN ASPHALT AREA

VALVE BOX AND LID FLUSH WITH GRADE
VALVE MARKER REQUIRED

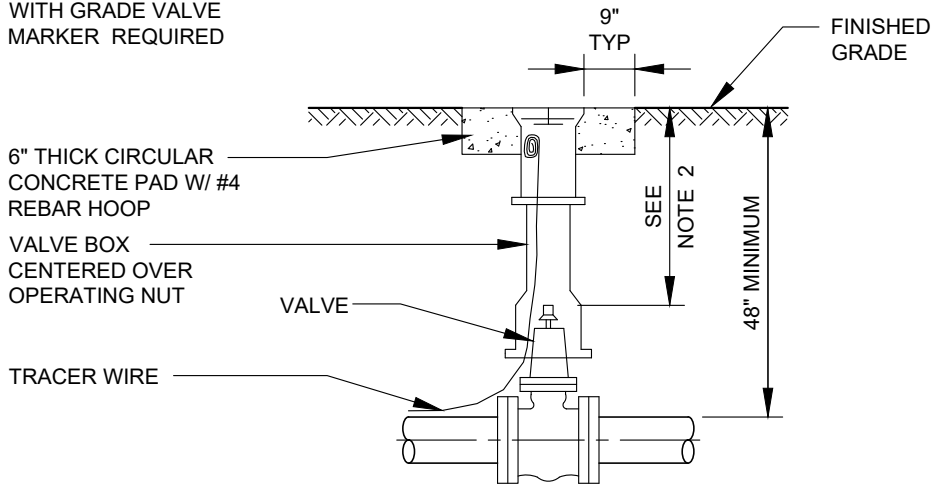

VALVE BOX IN UNIMPROVED AREA (VALVE MARKER REQUIRED)

NOTES

1. EACH VALVE SHALL BE PROVIDED WITH AN ADJUSTABLE CAST IRON VALVE BOX OF 5 INCHES (5") INSIDE DIAMETER. VALVE BOXES SHALL HAVE A TOP SECTION WITH AN EIGHTEEN INCH (18") MIN. LENGTH. THE VALVE BOX SHALL BE RICH No. 940 OR SATHER MANUFACTURING. VALVE BOX EARS SHALL BE PLACED IN LINE WITH PIPE IT SERVES.
2. 18" MINIMUM, 24" MAXIMUM FOR OPERATOR NUT IF EXTENSION IS REQUIRED.

M:\ROSLYN\23867 Construction Standards Update\Figures\WATER\W-4.dwg, 10/1/2024, 10:40 AM, FRANK PARKER



CITY OF ROSLYN
 CONSTRUCTION STANDARDS
DETAIL W-4
TYPICAL VALVE INSTALLATION



Gray & Osborne, Inc.
 CONSULTING ENGINEERS

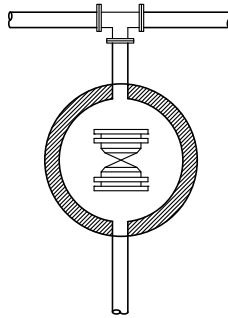

ALIGN "EARS" ON VALVE BOX TOP WITH DIRECTION OF PIPE BRANCH THE VALVE OPENS AND CLOSES.

PLAN VIEW

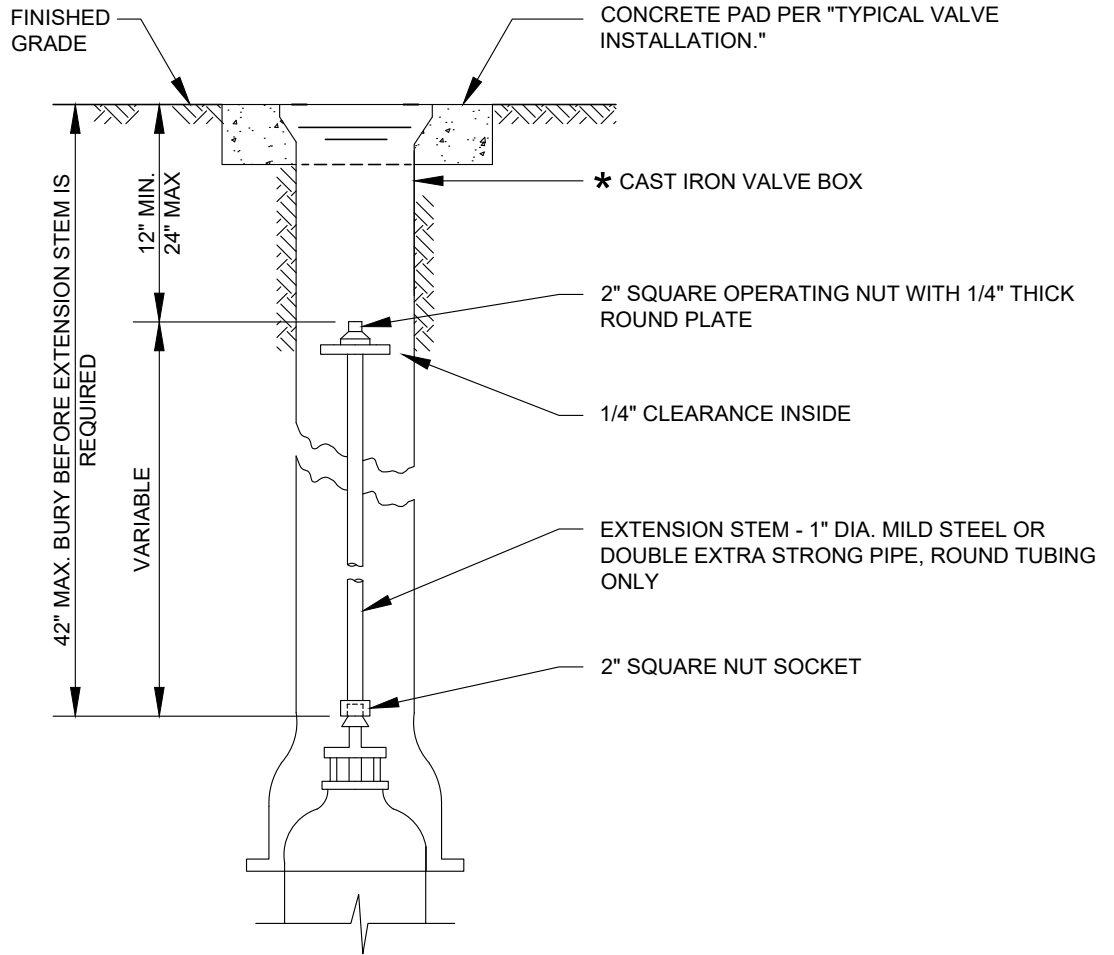

PROFILE VIEW

* CAST IRON VALVE BOX EXTENSION SHALL UTILIZE 5" CAST IRON "SOIL PIPE." BELL END TO BE PLACED OVER TOP OF VALVE BOX BOTTOM.

M:\ROSLYN\23867 Construction Standards Update\Figures\WATER\W-5.dwg, 10/1/2024 10:41 AM, FRANK PARKER



CITY OF ROSLYN
 CONSTRUCTION STANDARDS
DETAIL W-5
VALVE STEM EXTENSION



"CARSONITE" FIBERGLASS UTILITY
MARKER CUM375 WITH FLEXIBLE
ANCHOR BARB.
COLOR: APWA BLUE

3"x3" HIGH INTENSITY WHITE
REFLECTOR (250 CANDLE
POWER)

FINISHED GRADE

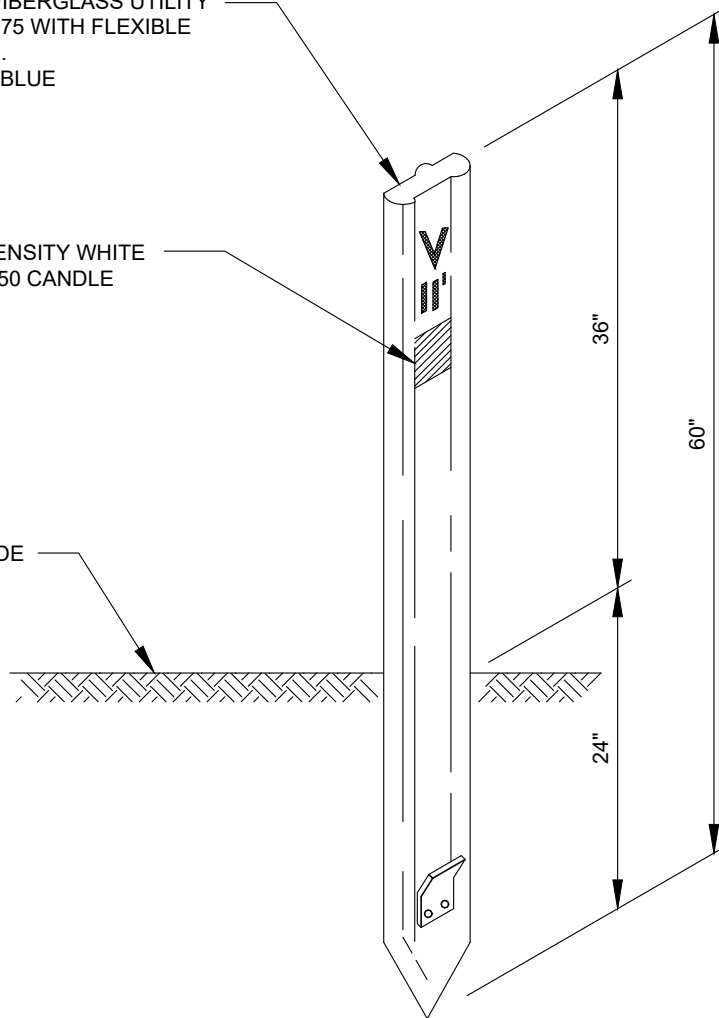

NOTES:

1. THE LETTER "V" AND THE DISTANCE IN FEET TO THE VALVE SHALL BE ON THE POST WITH 2" HIGH DECALS DESIGNED FOR USE ON FIBERGLASS BOATS.
2. EACH POST SHALL INCLUDE THE FOLLOWING DECAL: "CAUTION WATER VALVE, BEFORE DIGGING, CALL 811, UTILITY UNDERGROUND LOCATION CENTER."



CITY OF ROSLYN
CONSTRUCTION STANDARDS

DETAIL W-6
VALVE MARKER

Gray & Osborne, Inc.
CONSULTING ENGINEERS

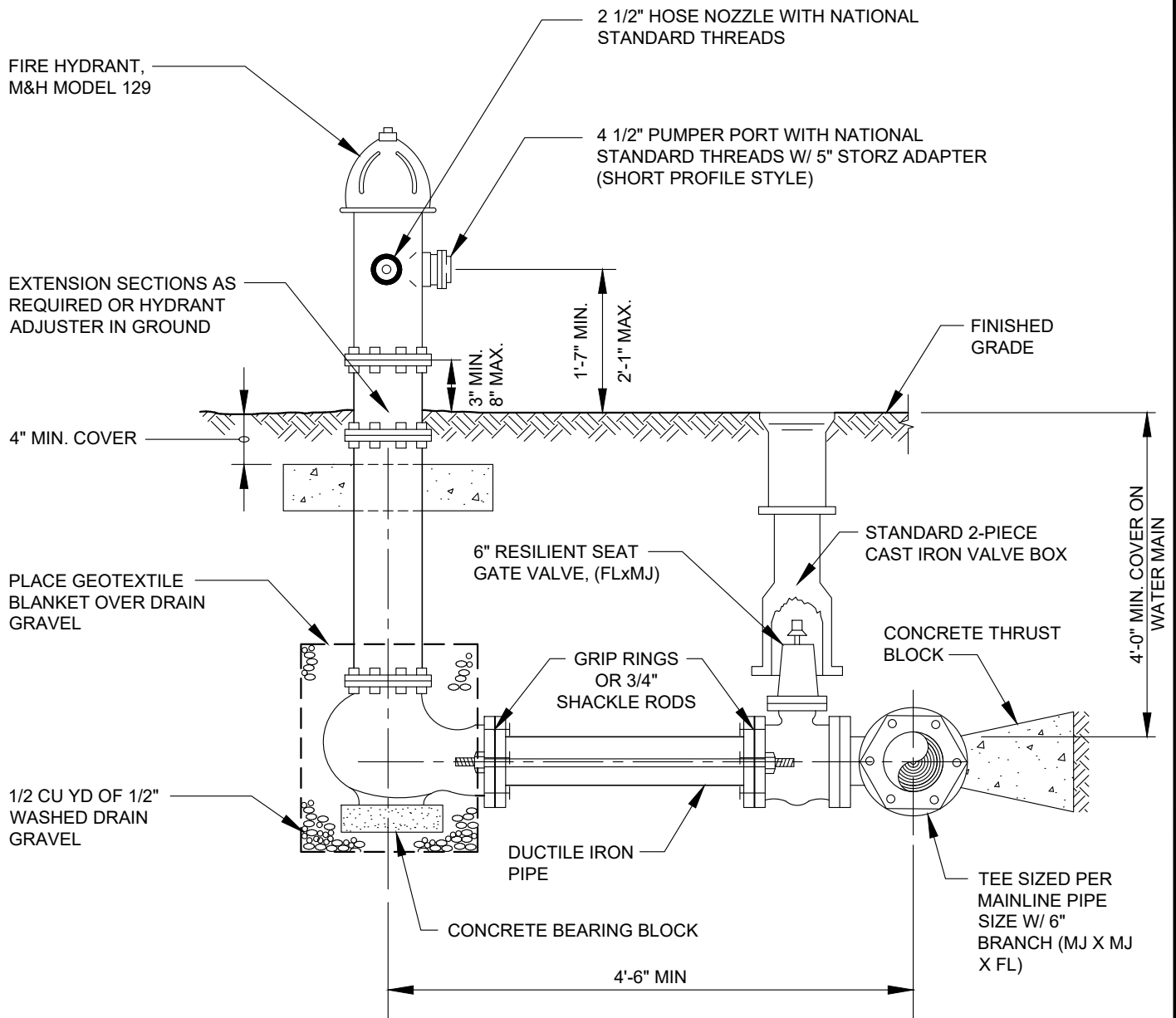

NOTES

1. PROVIDE MIN. 3'-0" CLEARANCE AND LEVEL AREA AROUND HYDRANT.
2. PAINT FIRE HYDRANT WITH TWO COATS OF YELLOW RUST-RESISTANT PAINT TO MATCH CITY'S EXISTING HYDRANTS.
3. ACCEPTABLE HYDRANTS: MUELLER SUPER CENTURION.
4. HYDRANT TEES SHALL BE MINIMUM OF 10 FEET FROM THE NEAREST TAP IN THE WATER MAIN.

M:\ROSLYN\23867 Construction Standards Update\Figures\WATER\W-7.dwg, 10/1/2024, 10:41 AM, FRANK PARKER



CITY OF ROSLYN
 CONSTRUCTION STANDARDS
DETAIL W-7
FIRE HYDRANT ASSEMBLY

Gray & Osborne, Inc.
 CONSULTING ENGINEERS

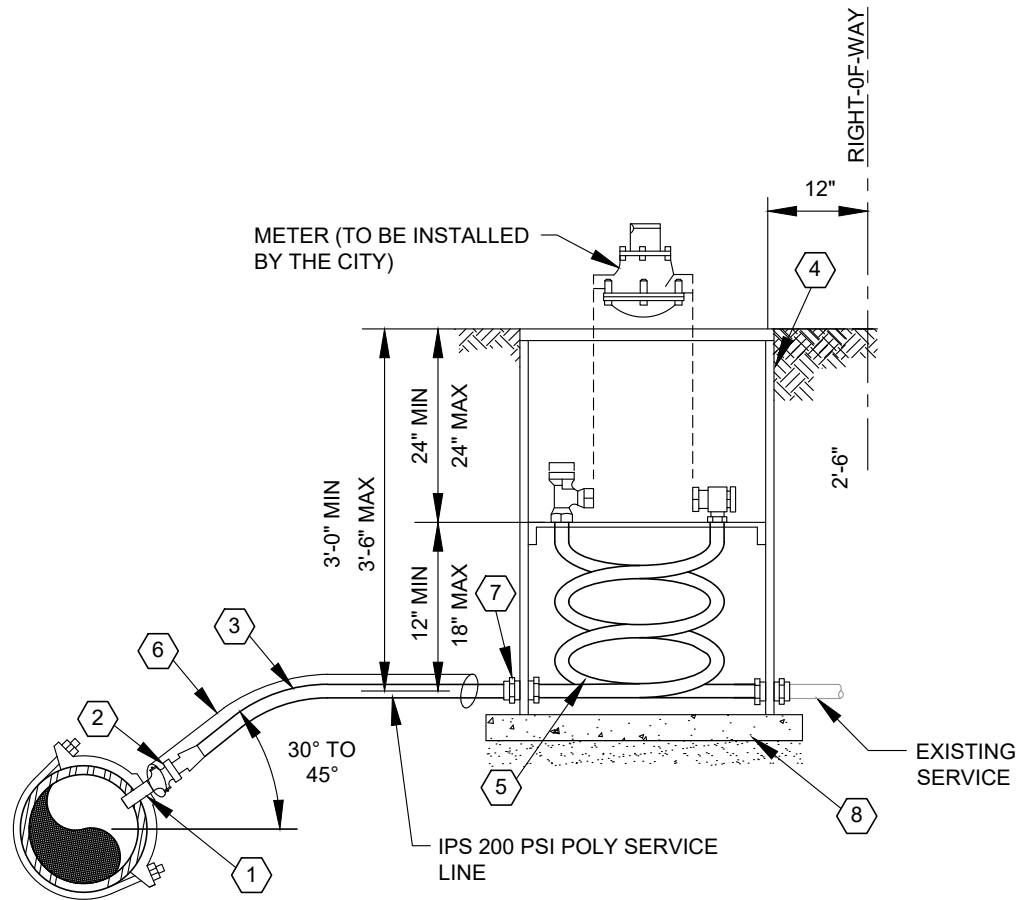

- ① FORD DOUBLE STRAP SERVICE SADDLE.
- ② CORPORATION STOP MUELLER H-15008.
- ③ 1" SDR 9 CTS PE4710 ASTM D-2737, AWWA 901, NSF CERTIFIED PIPING - LENGTH AS REQUIRED
- ④ BROOKS 12" X 20" METER BOX WITH H-20 RATED CAST IRON COVER.
- ⑤ FORD METER BOX CO. COIL PITSETTER, WITH ANGLE BALL AND SINGLE CHECK VALVE OR APPROVED EQUAL.
- ⑥ 14 GAUGE TRACER WIRE.
- ⑦ BRASS COUPLING, DIMENSIONS AS NECESSARY.
- ⑧ 15" DIA OR 18" DIA PITSETTER BLOCK.

NOTES:

1. SERVICE FROM METER BOX TO HOUSE BY PROPERTY OWNER.
2. INDIVIDUAL SERVICES REQUIRED FOR EACH LOT.
3. METER TO BE INSTALLED BY THE CITY AT OWNER'S EXPENSE.
4. COMPARABLE "FORD" FITTINGS MAY BE USED IN LIEU OF "MUELLER."

CITY OF ROSLYN
 CONSTRUCTION STANDARDS
DETAIL W-8
3/4" OR 1" WATER SERVICE



Gray & Osborne, Inc.
 CONSULTING ENGINEERS



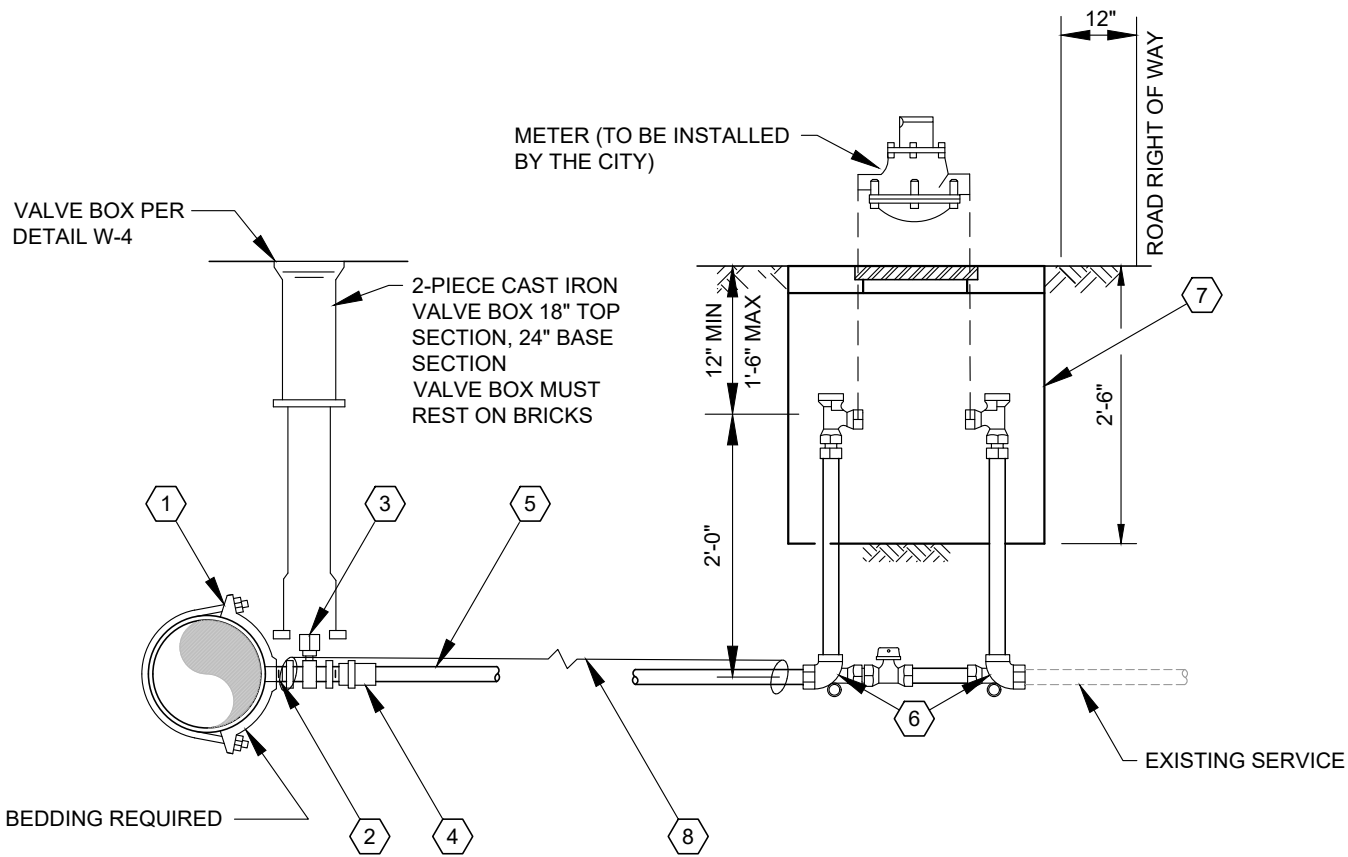

- 1 FORD DOUBLE STRAP SERVICE SADDLE
- 2 BRASS NIPPLE (3" MIN/6" MAX)
- 3 MUELLER B-20283 BALL VALVE WITH FORD OPERATING NUT ADAPTER QT-67
- 4 STRAIGHT COUPLING MUELLER H-15428 COMPRESSION x MIP
- 5 1-1/2" OR 2" SDR 9 CTS PE4710 ASTM D-2737, AWWA 901, NSF CERTIFIED PIPING - LENGTH AS REQUIRED
- 6 FORD 70 SERIES COPPERSETTER WITH BALL VALVE INLET AND OUTLET
- 7 BROOKS 17"x30" METER BOX WITH H-20 RATED CAST IRON COVER
- 8 14 GAUGE TRACER WIRE

NOTES:

1. SERVICE FROM METER BOX TO HOUSE BY PROPERTY OWNER INDIVIDUAL SERVICES REQUIRED FOR EACH PROPERTY.
2. METER TO BE INSTALLED BY THE CITY AT THE OWNER'S EXPENSE.
3. COMPARABLE "FORD" FITTINGS MAY BE USED IN LIEU OF "MUELLER."

M:\ROSLYN\23867 Construction Standards Update\Figures\WATER\W-9.dwg, 10/1/2024, 10:41 AM, FRANK PARKER



CITY OF ROSLYN
 CONSTRUCTION STANDARDS
DETAIL W-9
1-1/2" OR 2" WATER SERVICE



Gray & Osborne, Inc.
 CONSULTING ENGINEERS

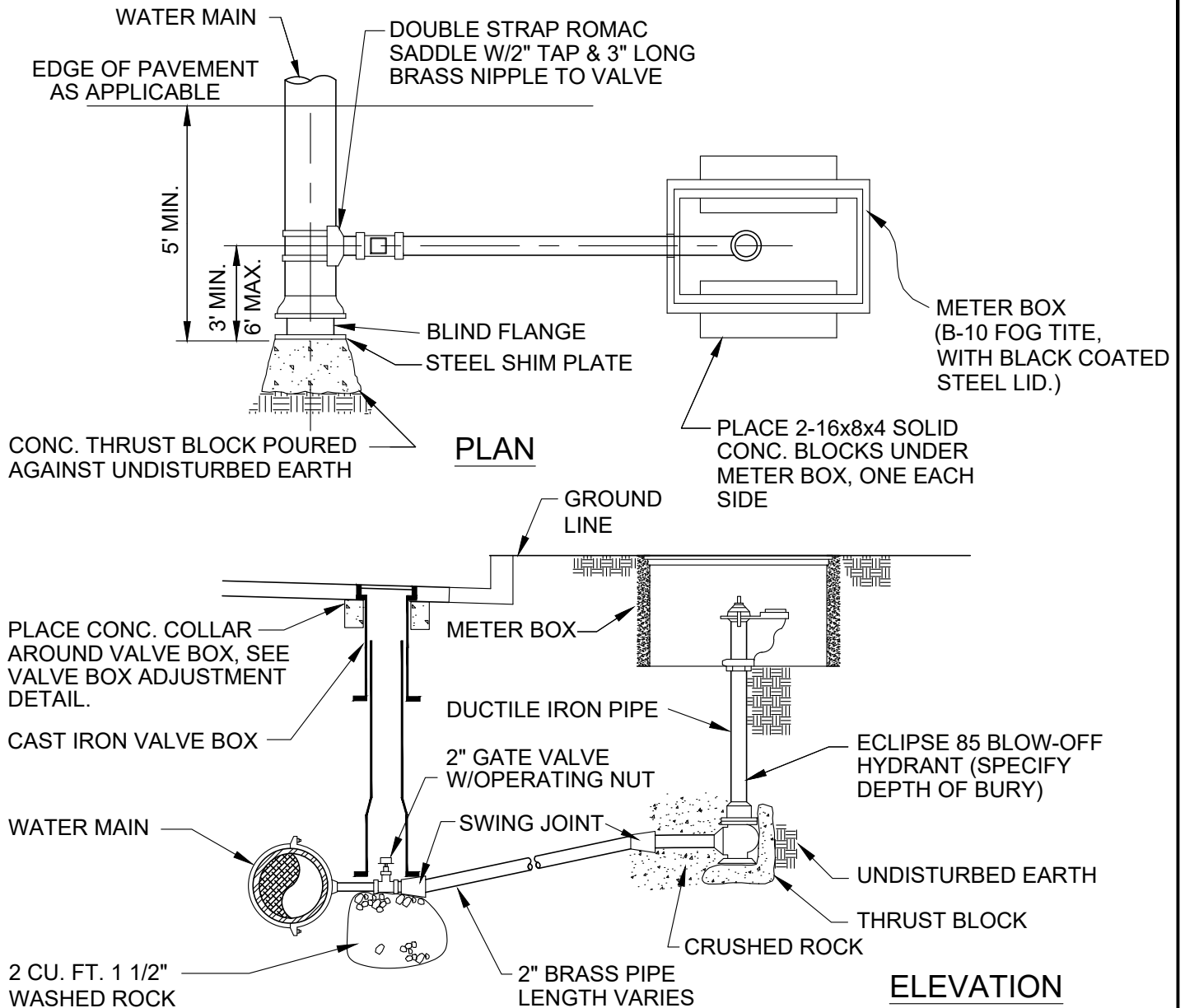

BLOW-OFF HYDRANTS SHALL BE NON-FREEZING, SELF-DRAINING TYPE.

1. SET UNDERGROUND IN CITY APPROVED METER BOX, THESE HYDRANTS WILL BE FURNISHED WITH A 2" FIP INLET, A NON-TURNING OPERATING ROD, AND SHALL OPEN TO THE DESIGN, AND BE SERVICEABLE FROM ABOVE GRADE WITH NO DIGGING.
2. THE OUTLET SHALL ALSO BE BRONZE AND BE 2-1/2" NST.
3. HYDRANTS SHALL BE LOCKABLE TO PREVENT UNAUTHORIZED USE. (SPECIFY OVERALL LENGTH 6" SHORTER THAN NORMAL DEPTH OF BURY. MINIMUM OPENING IN METER BOX SHALL BE 10".)



CITY OF ROSLYN
CONSTRUCTION STANDARDS
DETAIL W-10
BLOW OFF ASSEMBLY



M:\ROSLYN\23867 Construction Standards Update\Figures\WATERW-11.dwg, 10/1/2024 10:42 AM, FRANK PARKER

9" X 4' CONCRETE POST
ATTACH VENT TO POST
2" - 180° OPEN PATTERN
RETURN BEND
2" 24 MESH SS SCREEN
AIR GAP: MIN 2 1/2 x PIPE
DIA MAX 18"

2" GALV IRON PIPE FIELD LOCATE
2"x2"x1" TEE, 1" CLOSE NIPPLE,
1" - 90° BEND
1" GALV IRON PIPE TO FIT
2" GALV IRON PIPE 18" LONG

2" CAP WITH 1/8" HOLE FOR
DRAIN

12" MIN

1" GALV IRON NIPPLES

WASHED GRAVEL PASSING 1 1/2" AND
RETAINED ON 1/4" MESH

1" UNION
1" GALV. IRON NIPPLES
1" 90° BEND
1" GALV. IRON NIPPLES
FILL BOX
WITH SAWDUST

4" PIPE
OVER VALVE
CONCRETE METER BOX (2 SECTIONS
REQUIRED) FOG-TITE METER SEAL Co.
No.2 METER BOX, WITH 3/8" STEEL
PLATE COVER
1" AIR AND VACUUM RELEASE VALVE,
APCO 143C, OR EQUAL
1" BRONZE GATE VALVE, THREAD
RED-WHITE VALVE CORP. FIG. No.280,
OHIO BRASS #2500

14 GAUGE
TRACER WIRE
1" HDPE PIPE (CTS 250 PSI)

FORD F.500 1" CORPORATION
STOP INLET IPT & IPT OUTLET

BRASS 90° ELBOW

1" GALV IRON NIPPLES
1" UNION
1" GALV IRON NIPPLES
1" 90° BEND

COUPLING C85-44 TO MALE
IRON PIPE-FORD

FORD DOUBLE STRAP
SERVICE SADDLE



CITY OF ROSLYN
CONSTRUCTION STANDARDS
DETAIL W-11
**1" AIR AND VACUUM RELEASE
ASSEMBLY**



Gray & Osborne, Inc.
CONSULTING ENGINEERS

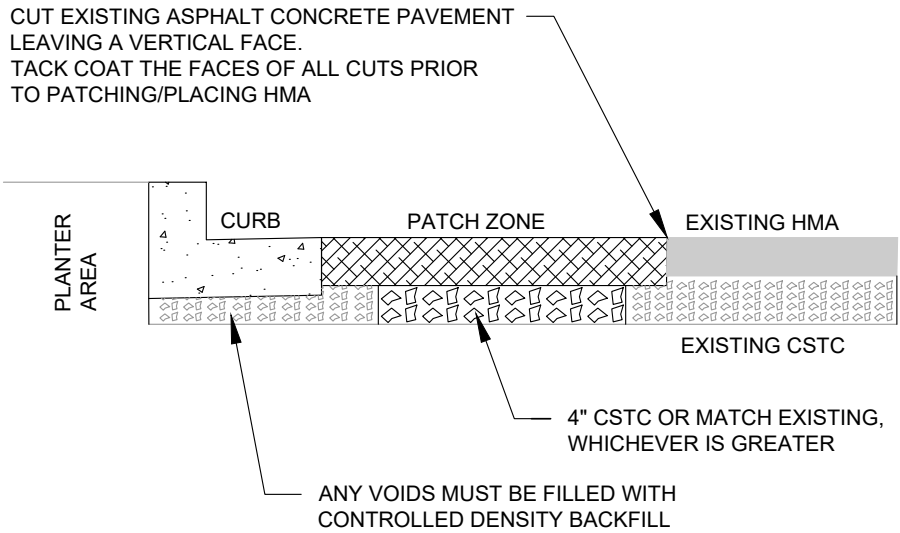

NOTES:

1. HMA IN THE PATCH ZONE SHALL BE A MINIMUM OF 3" THICK, OR MATCH EXISTING, WHICHEVER IS GREATER. HOWEVER, THE MAXIMUM THICKNESS IS NOT REQUIRED TO BE GREATER THAN 6". ALL PATCHES SHALL BE PLACED IN A MINIMUM OF 2 LIFTS. MAXIMUM DEPTH OF LIFTS SHALL BE 2" (COMPACTED).
2. PATCH WIDTH MUST ACCOMMODATE PROPER COMPACTION METHODS AS APPROVED BY THE CITY AND COORDINATE WITH LANE WIDTHS.
3. ALL CONSTRUCTION AND MATERIALS SHALL MEET THE WSDOT SPECIFICATIONS AND BE APPROVED BY THE CITY.

M:\ROSLYN\23867 Construction Standards Update\Figures\WATERW-12.dwg, 10/1/2024 10:42 AM, FRANK PARKER



CITY OF ROSLYN
 CONSTRUCTION STANDARDS
DETAIL W-12
TRENCH PATCH



Gray & Osborne, Inc.
 CONSULTING ENGINEERS



NOTES:

1. MUNICIPAL UTILITIES SHALL BE INSTALLED WITHIN DEDICATED RIGHT-OF-WAY UNLESS A DEVIATION IS APPROVED.
2. MUNICIPAL UTILITIES THAT ARE APPROVED TO BE INSTALLED OUTSIDE OF THE RIGHT-OF-WAY SHALL BE INSTALLED WITHIN A MUNICIPAL EASEMENT AND ACCESS ROADWAY PER THIS DETAIL. THE DEVELOPER MAY SUBMIT AN ALTERNATE PLAN FOR APPROVAL. THE CITY MAY WAIVE THE REQUIREMENT FOR AN ACCESS ROAD IF ALL UTILITY STRUCTURES CAN BE SERVICED BY AN APPROVED ROADWAY.
3. ACCESS ROADWAY SHALL BE CSBC OR CSTC, MINIMUM 3" DEPTH, AND DESIGNED FOR 50,000 lb MAINTENANCE VEHICLES.
4. UTILITY STRUCTURES SHALL BE CENTERED AT LEAST 1' FROM THE OUTER EDGE OF RIGHT-OF-WAY OR MUNICIPAL EASEMENT.
5. UTILITY STRUCTURES THAT ARE MORE THAN 10' DEEP SHALL REQUIRE ADDITIONAL RIGHT-OF-WAY OR MUNICIPAL EASEMENT WIDTHS.
6. 6'x6'x6" CONCRETE PADS ARE REQUIRED AROUND ALL UTILITY STRUCTURES THAT ARE INSTALLED IN NON-ASPHALT AREAS.
7. ACCESS ROADWAY SHALL DRAIN AWAY FROM UTILITY STRUCTURE.
8. ALL CONSTRUCTION AND MATERIALS SHALL MEET THE WSDOT SPECIFICATIONS AND BE APPROVED BY THE CITY.

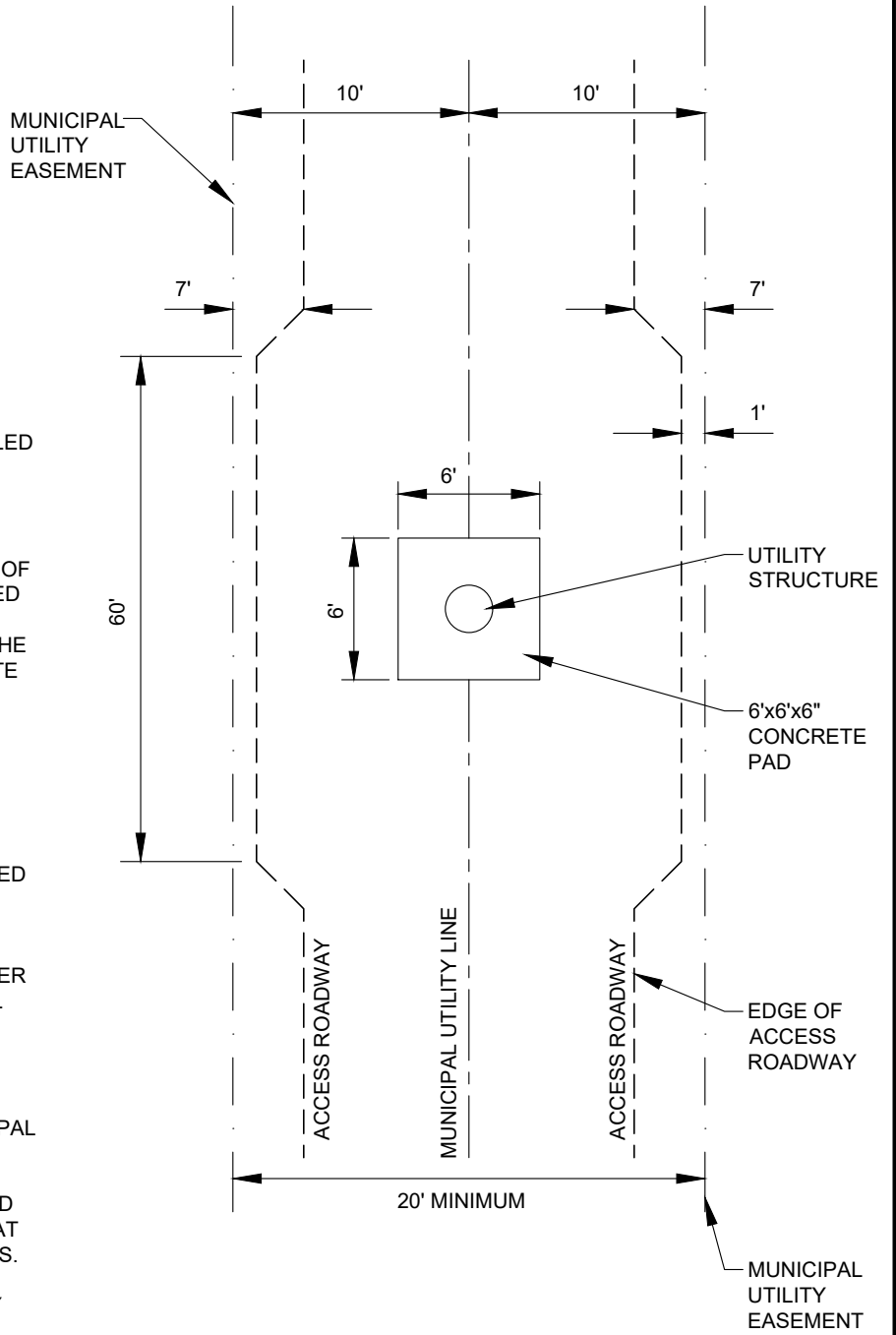

CITY OF ROSLYN
 CONSTRUCTION STANDARDS
DETAIL W-13
ACCESS EASEMENT AND
ROADWAY FOR MUNICIPAL
UTILITIES



Gray & Osborne, Inc.
 CONSULTING ENGINEERS

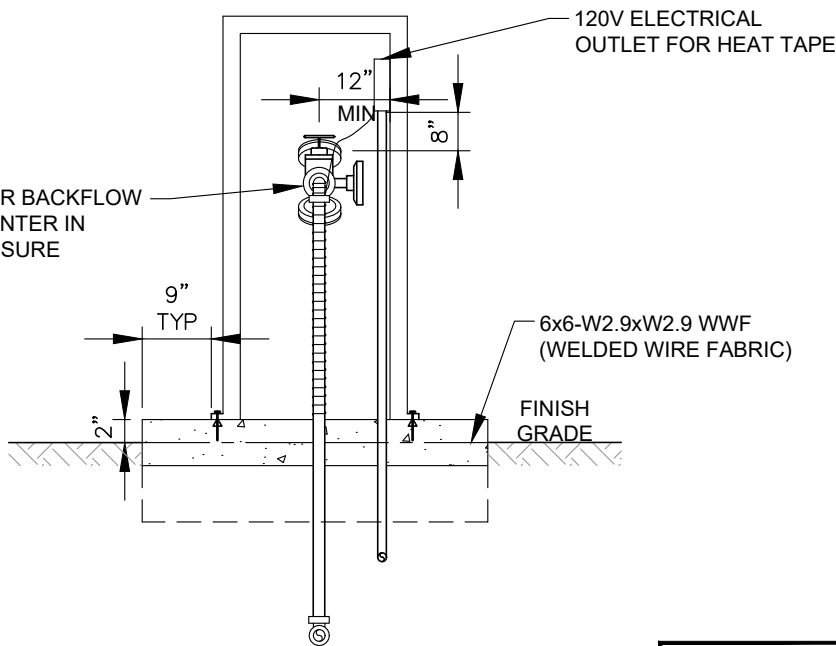
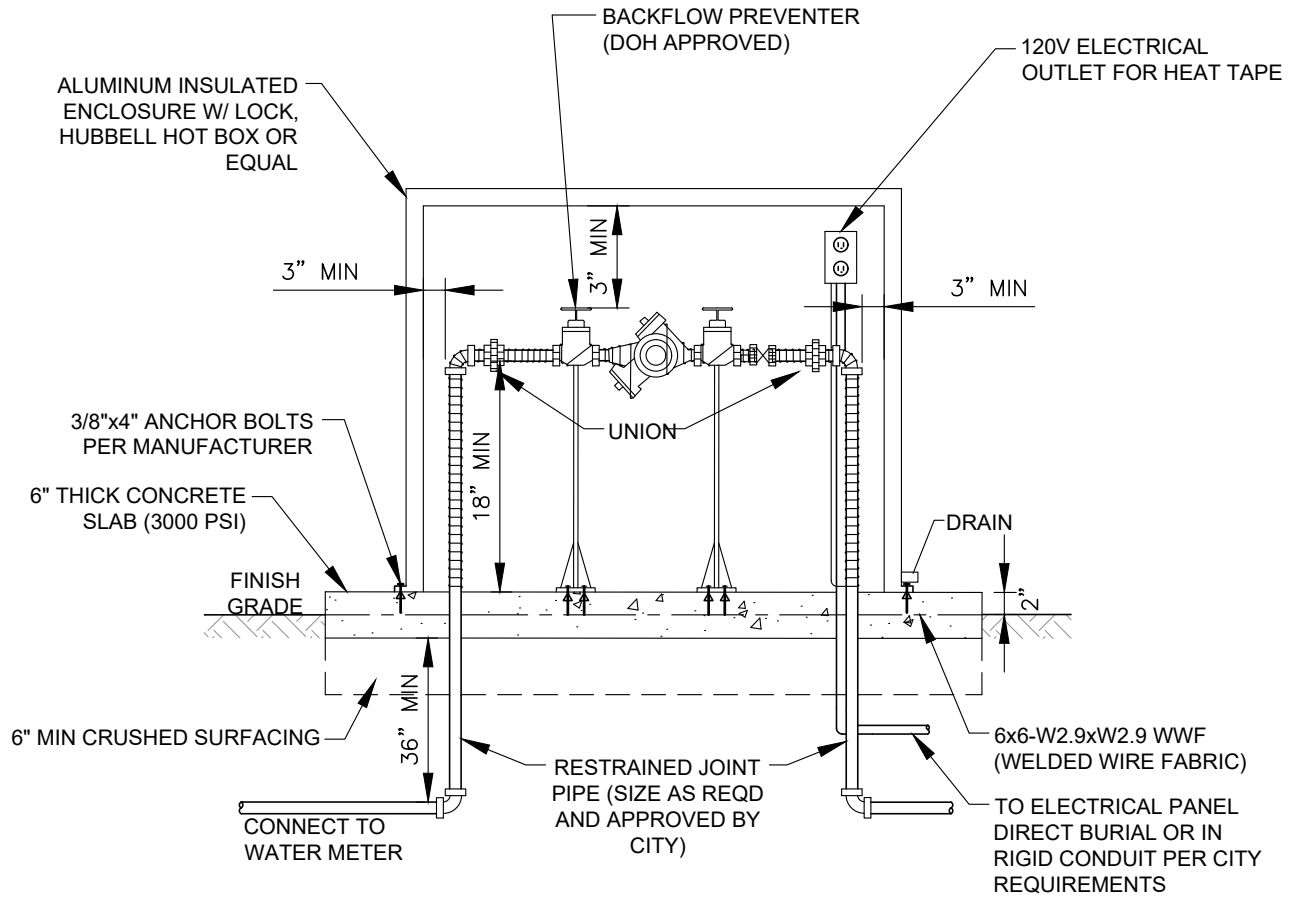

NOTE:

PROVIDE CITY APPROVED SUPPORT FOR 2 1/2" AND LARGER DEVICES.



CITY OF ROSLYN
 CONSTRUCTION STANDARDS
DETAIL W-14
REDUCED PRESSURE
BACKFLOW ASSEMBLY



STORM DETAILS

SURFACE REPAIR REQUIREMENTS SHALL BE DETERMINED BY CITY

FINISHED GRADE

6" WIDE DETECTABLE MARKING TAPE

BACKFILL MATERIAL CONSISTING OF SUITABLE EXCAVATED MATERIAL OR BANK RUN GRAVEL FOR TRENCH BACKFILL

SPECIAL PRECAUTIONS TO PROTECT PIPE TO THIS LEVEL

14 GAUGE TRACER WIRE, TAPE TO TOP OF PIPE

STORM DRAIN PIPE AS SPECIFIED PER CITY STANDARDS

GRAVEL BACKFILL FOR PIPE BEDDING, CRUSHED SURFACING TOP COURSE OR APPROVED BEDDING MATERIAL

FOUNDATION GRAVEL AS REQUIRED

MINIMUM TRENCH WIDTH - "W"

	MINIMUM PIPE COVER "L"	MINIMUM PIPE DIAMETER "D"
STORM SEWER UNDER ROADWAY	36 INCHES	12 INCH
STORM SEWER UNDER SIDEWALK	24 INCHES	12 INCH
STORM SEWER - DUCTILE IRON	18 INCHES	12 INCH

NOTE:

MINIMUM TRENCH WIDTH FOR MAINS IS PIPE SIZE PLUS 18 INCHES. ALL TRENCHES SHALL MEET WAC CHAPTER 298-155 FOR CONSTRUCTION WORK.

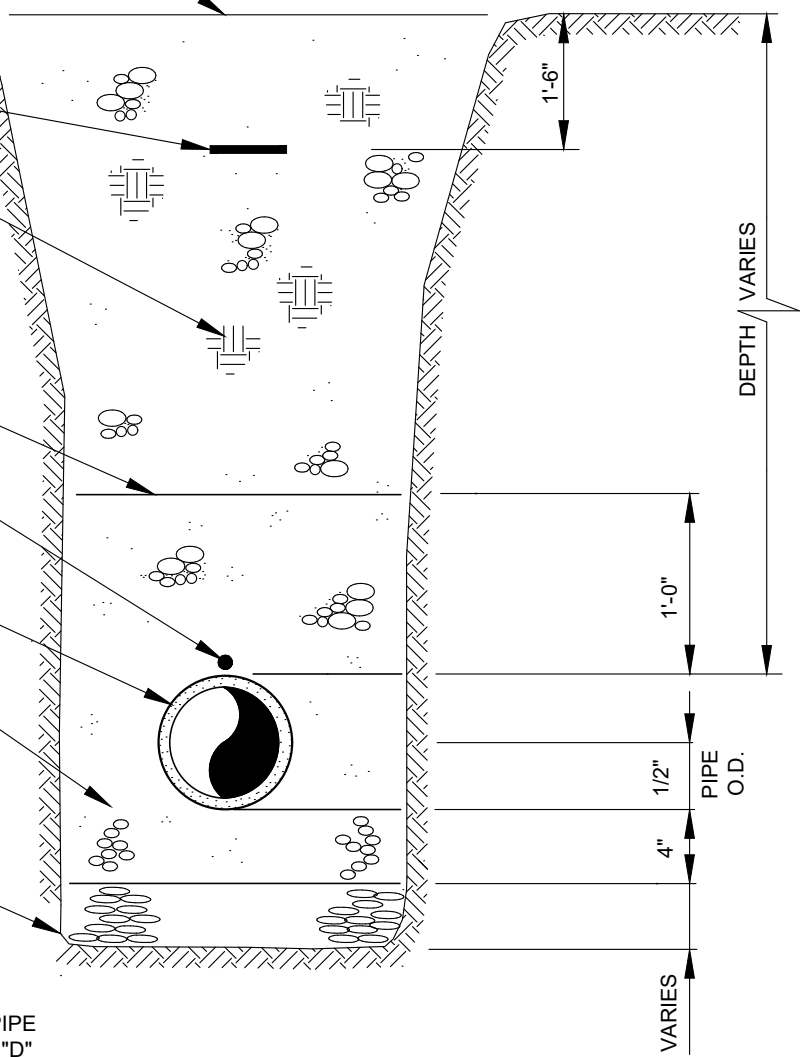

M:\ROS\YN\23867 Construction Standards Update\Figures\STORM\SD-1.dwg, 10/1/2024 10:46 AM, FRANK PARKER



CITY OF ROSLYN
 CONSTRUCTION STANDARDS
DETAIL SD-1
STORM DRAIN TRENCH SECTION



Gray & Osborne, Inc.
 CONSULTING ENGINEERS

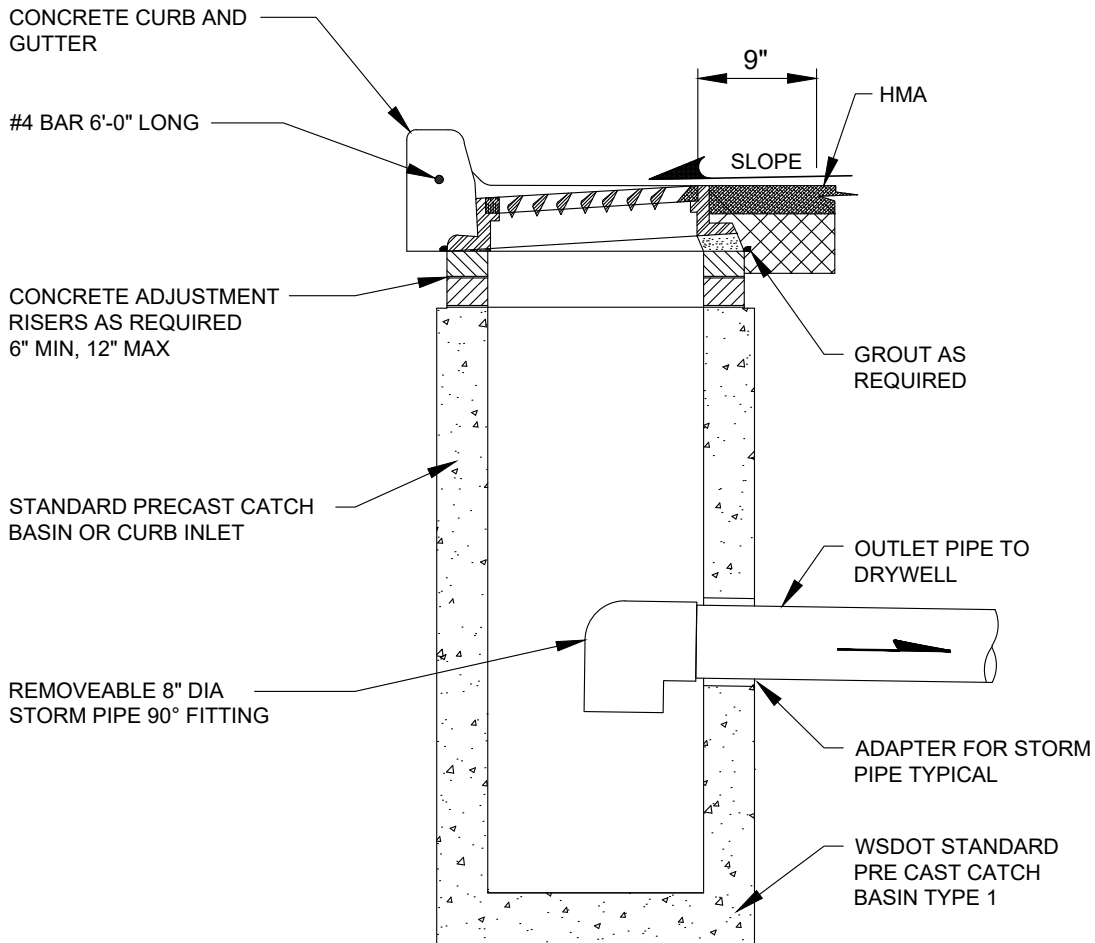
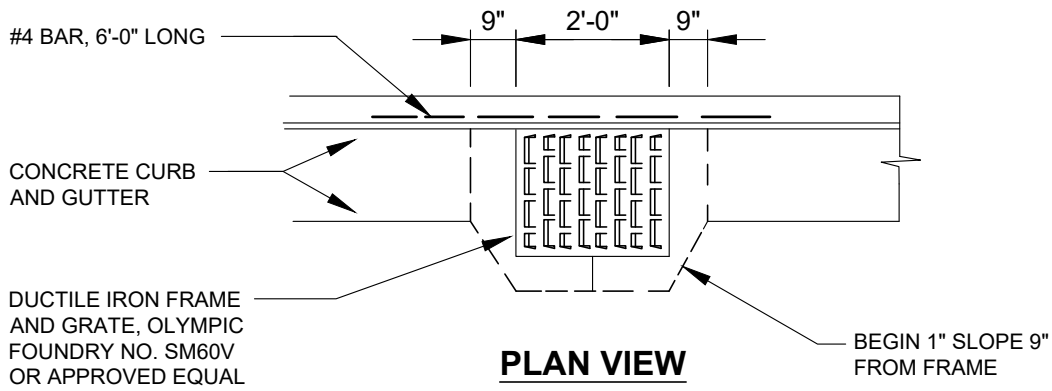

PROFILE VIEW

CITY OF ROSLYN
 CONSTRUCTION STANDARDS
 DETAIL SD-2
 CATCH BASIN - TYPE 1



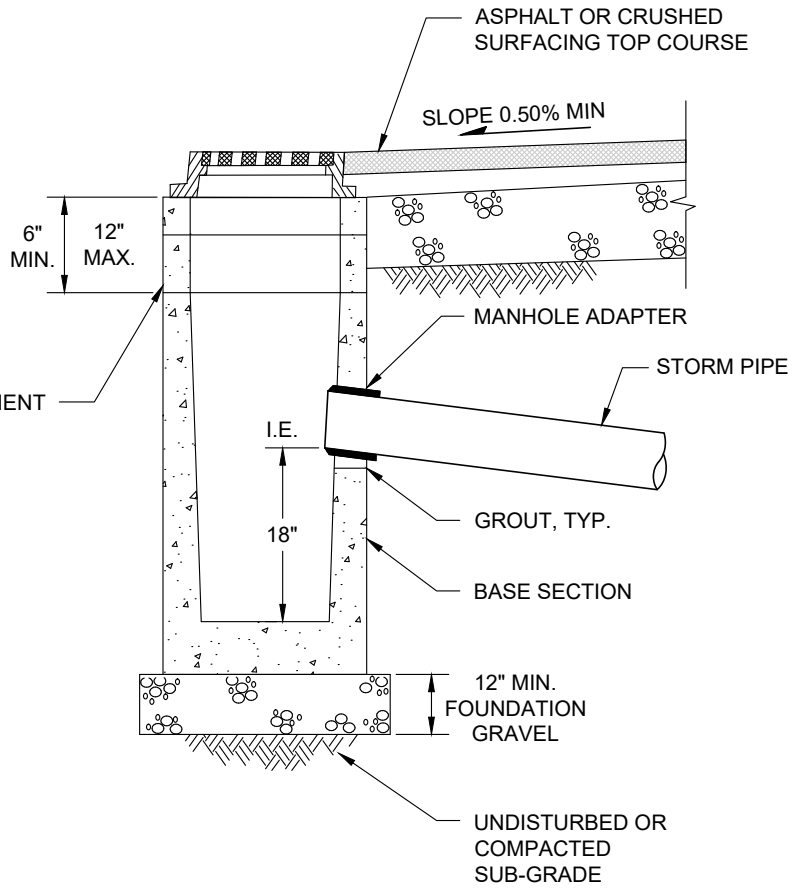

NOTE:

FOR PIPE INSTALLATION, REFER TO
STORM SEWER TRENCH SECTION
DETAIL.

M:\ROS\YN\23867 Construction Standards Update\Figures\STORM\SD-3.dwg, 10/1/2024 10:46 AM, FRANK PARKER



CITY OF ROSLYN
 CONSTRUCTION STANDARDS
DETAIL SD-3
CATCH BASIN - TYPE 1A



Gray & Osborne, Inc.
 CONSULTING ENGINEERS

M:\ROSLYN\23867 Construction Standards Update\Figures\STORM\SD-4.dwg, 10/11/2024, 10:46 AM, FRANK PARKER

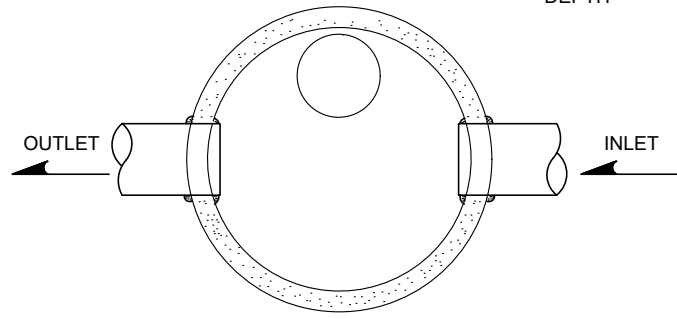
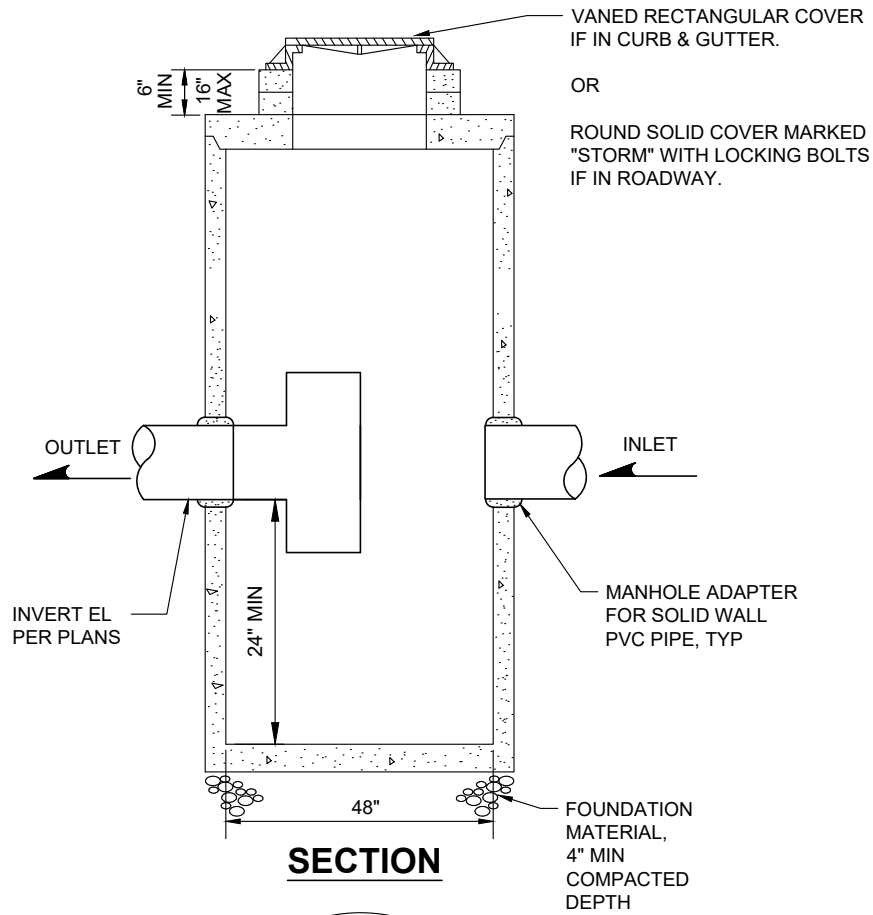

NOTES:

1. CATCH BASINS AND CONCRETE INLETS TO BE CONSTRUCTED TO ASTM C 478 (AASHTO M 199) AND ASTM C 890 UNLESS OTHERWISE SHOWN ON PLANS OR NOTED IN THE STANDARD SPECIFICATIONS.
2. AS AN ACCEPTABLE ALTERNATE TO REBAR, WELDED WIRE FABRIC HAVING A MINIMUM AREA OF 0.12 SQUARE INCHES PER FOOT MAY BE USED. WELDED WIRE FABRIC SHALL COMPLY TO ASTM A 497 (AASHTO M 221). WIRE FABRIC SHALL NOT BE PLACED IN THE KNOCKOUTS.
3. THE BOTTOM OF THE PRECAST BASE SECTION MAY BE ROUNDED
4. PRECAST BASES SHALL BE FURNISHED WITH CUTOUTS OR KNOCKOUTS. KNOCKOUTS SHALL HAVE A WALL THICKNESS OF 2" MINIMUM.
5. KNOCKOUTS MAY BE ON ALL 4 SIDES WITH MAXIMUM DIAMETER OF 20". KNOCKOUTS MAY BE EITHER ROUND OR "D" SHAPE. PIPE TO BE INSTALLED IN FACTORY SUPPLIED KNOCKOUTS.
6. KNOCKOUT OR CUTOUT HOLE SIZE IS EQUAL TO PIPE OUTER DIAMETER
7. WHERE CONNECTIONS TO EXISTING PIPES ARE CALLED OUT ON THE PLANS, CONNECTIONS SHALL USE FERNCO, ROMAC, OR AN APPROVED EQUAL TO CONNECT.

NOTES:

1. PIPE SIZES AND SLOPES TO BE PER PLANS
2. FRAME AND LADDER OR STEPS SHALL BE OFFSET TO PROVIDE:
 - 2.1. CLIMB-DOWN SPACE IS CLEAR OF RISER AND CLEANOUT GRATE.
 - 2.2. FRAME IS CLEAR OF SIDEWALK AND/OR CURB



CITY OF ROSLYN
CONSTRUCTION STANDARDS

DETAIL SD-4
CATCH BASIN - TYPE 2

Gray & Osborne, Inc.
 CONSULTING ENGINEERS

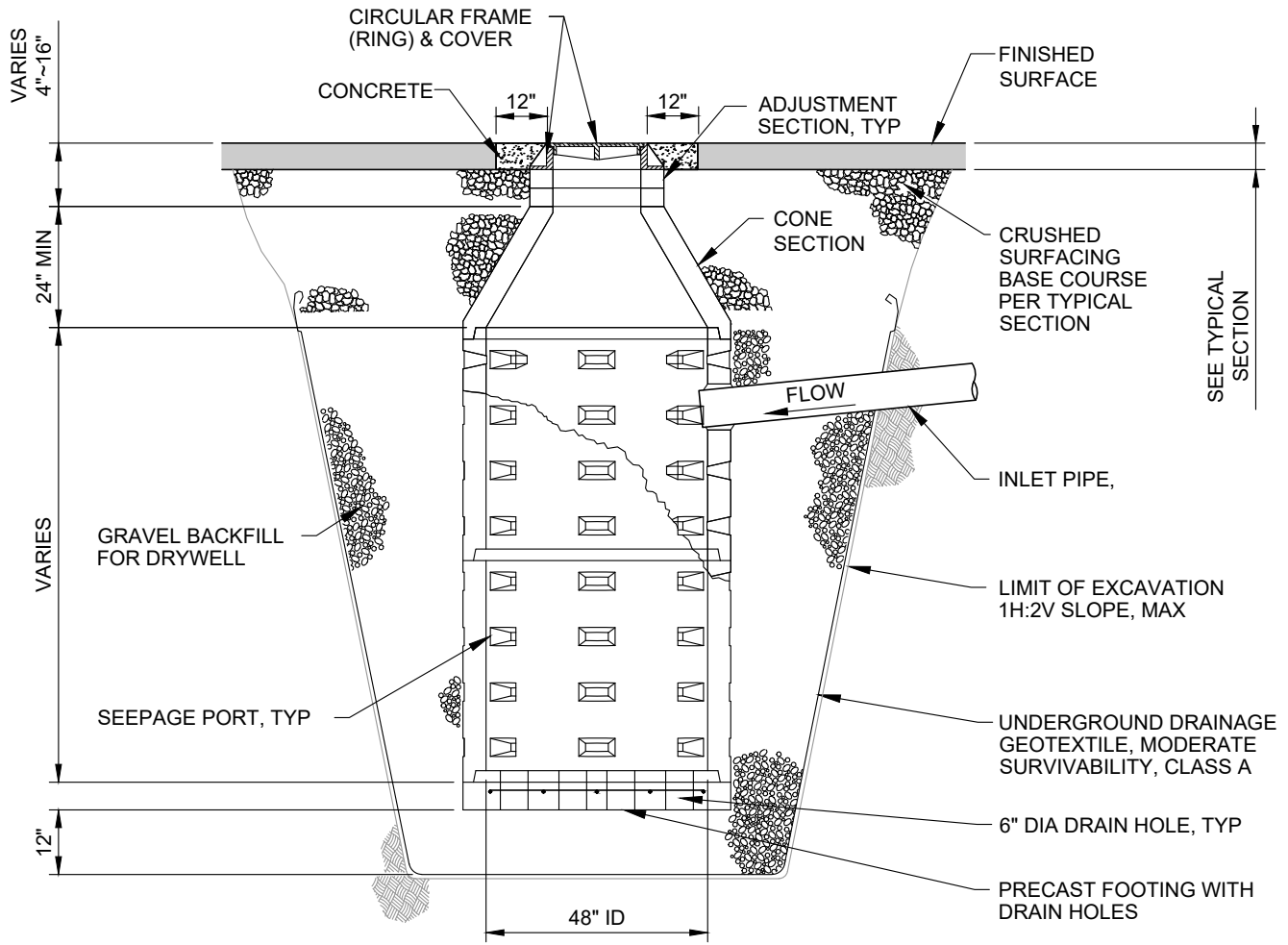

NOTES:

1. MINIMUM OF ONE 4-INCH ADJUSTMENT RING WITH A MAXIMUM OF 16 INCHES OF ADJUSTMENT.
2. PRECAST CONE SECTION MAY BE CONCENTRIC OR ECCENTRIC.
3. DRYWELLS NOT IN SIDEWALK SHALL BE PLACED IN A 6-FT. BY 6-FT. BY 6-IN. CONCRETE PAD AT FINISH GRADE.
4. "STORM" SHALL BE CAST IN THE LID AND FRAME AND GRATE SHALL COMPLY WITH SEC. 9-05.15(1) OF THE WSDOT SPECIFICATIONS.
5. ANY USE OF DRYWELL SHALL BE DOCUMENTED BY GEOTECH.

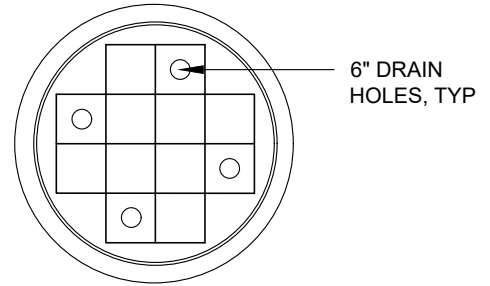

PRECAST FOOTING DETAIL

M:\ROSLYN\23867 Construction Standards Update\Figures\STORM\SD-5.dwg, 10/1/2024 10:46 AM, FRANK PARKER



CITY OF ROSLYN
 CONSTRUCTION STANDARDS
DETAIL SD-5
PRECAST CONCRETE DRYWELL

Gray & Osborne, Inc.
 CONSULTING ENGINEERS

M:\ROSLYN\23867 Construction Standards Update\Figures\STORM\SD-6.dwg, 10/1/2024 10:47 AM, FRANK PARKER

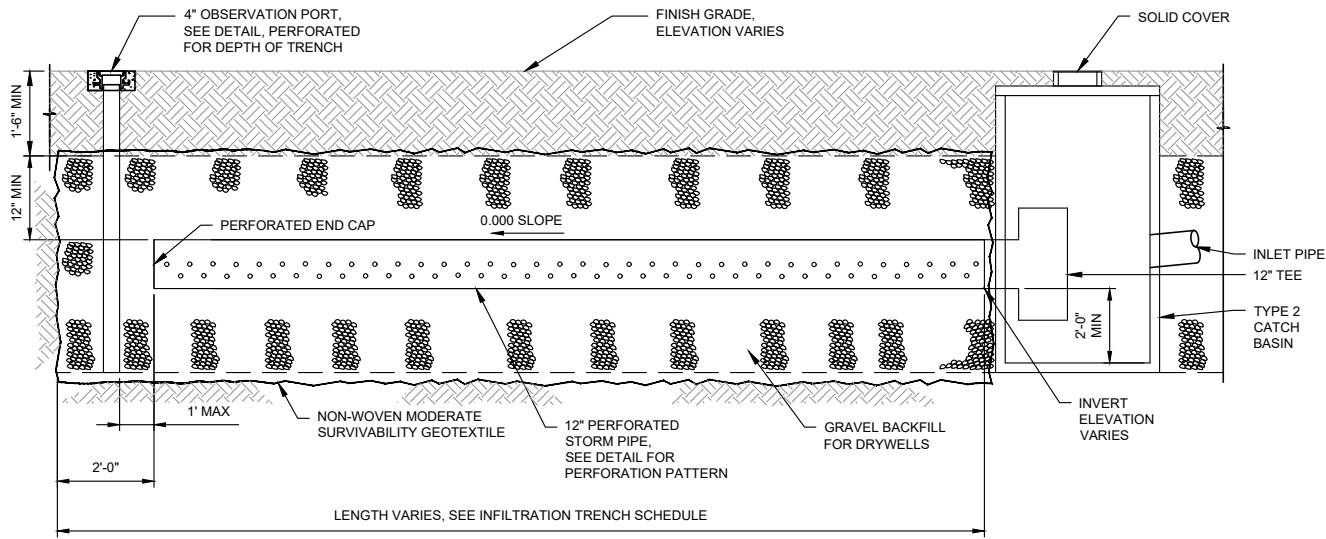

SIDE VIEW

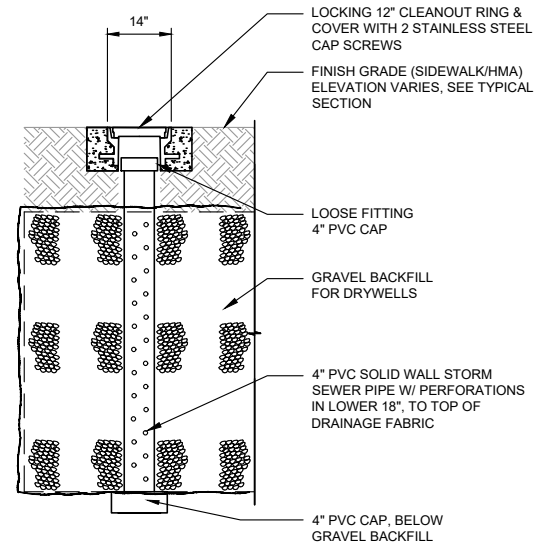

OBSERVATION PORT

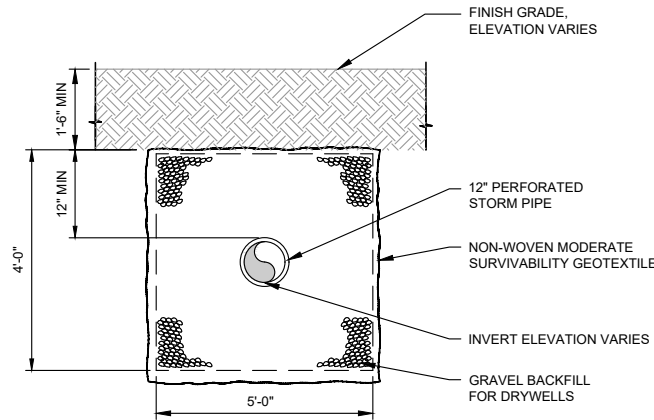

SECTION VIEW



CITY OF ROSLYN
CONSTRUCTION STANDARDS
DETAIL SD-6
INFILTRATION TRENCH

Gray & Osborne, Inc.
 CONSULTING ENGINEERS

SEWER DETAILS

SURFACE REPAIR REQUIREMENTS
TO BE DETERMINED BY CITY

FINISHED GRADE OR
SUBGRADE

COMPACTED BACKFILL CONSISTING
OF SUITABLE EXCAVATED MATERIAL
OR BANK RUN GRAVEL FOR TRENCH
BACKFILL

6" WIDE DETECTABLE MARKING
TAPE

SPECIAL PRECAUTIONS TO PROTECT
PIPE TO THIS LEVEL

14 GAUGE TRACER WIRE, TAPE TO TOP
OF PIPE

PVC SEWER PIPE

GRAVEL BACKFILL FOR PIPE BEDDING,
CRUSHED SURFACE TOP COURSE OR
APPROVED PIPE BEDDING MATERIAL

FOUNDATION GRAVEL AS REQUIRED

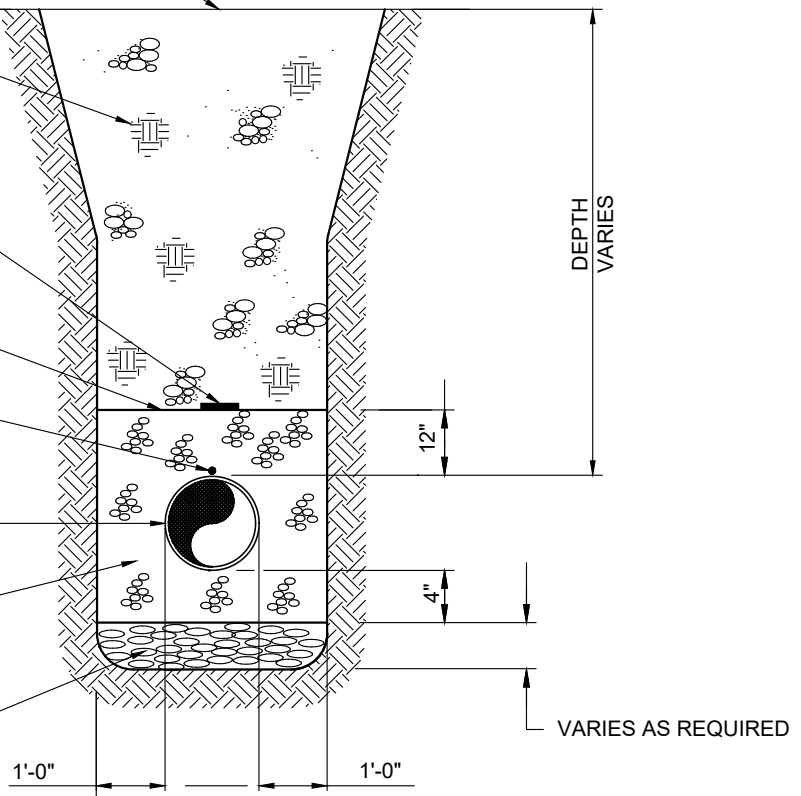

NOTE:

ACTUAL SLOPE OF TRENCH SIDES TO BE
DETERMINED BY CONTRACTOR TO FIT THE METHOD
OF CONSTRUCTION AND ALL SAFETY
REQUIREMENTS.

NOTE:

MINIMUM TRENCH WIDTH FOR MAINS IS PIPE SIZE
PLUS 18 INCHES. ALL TRENCHES SHALL MEET
WAC CHAPTER 298-155 FOR CONSTRUCTION WORK.

M:\ROS\YN\23867 Construction Standards Update\Figures\SEWER\SS-1.dwg, 10/1/2024 10:50 AM, FRANK PARKER



CITY OF ROSLYN
CONSTRUCTION STANDARDS
DETAIL SS-1
SANITARY SEWER
TYPICAL TRENCH SECTION



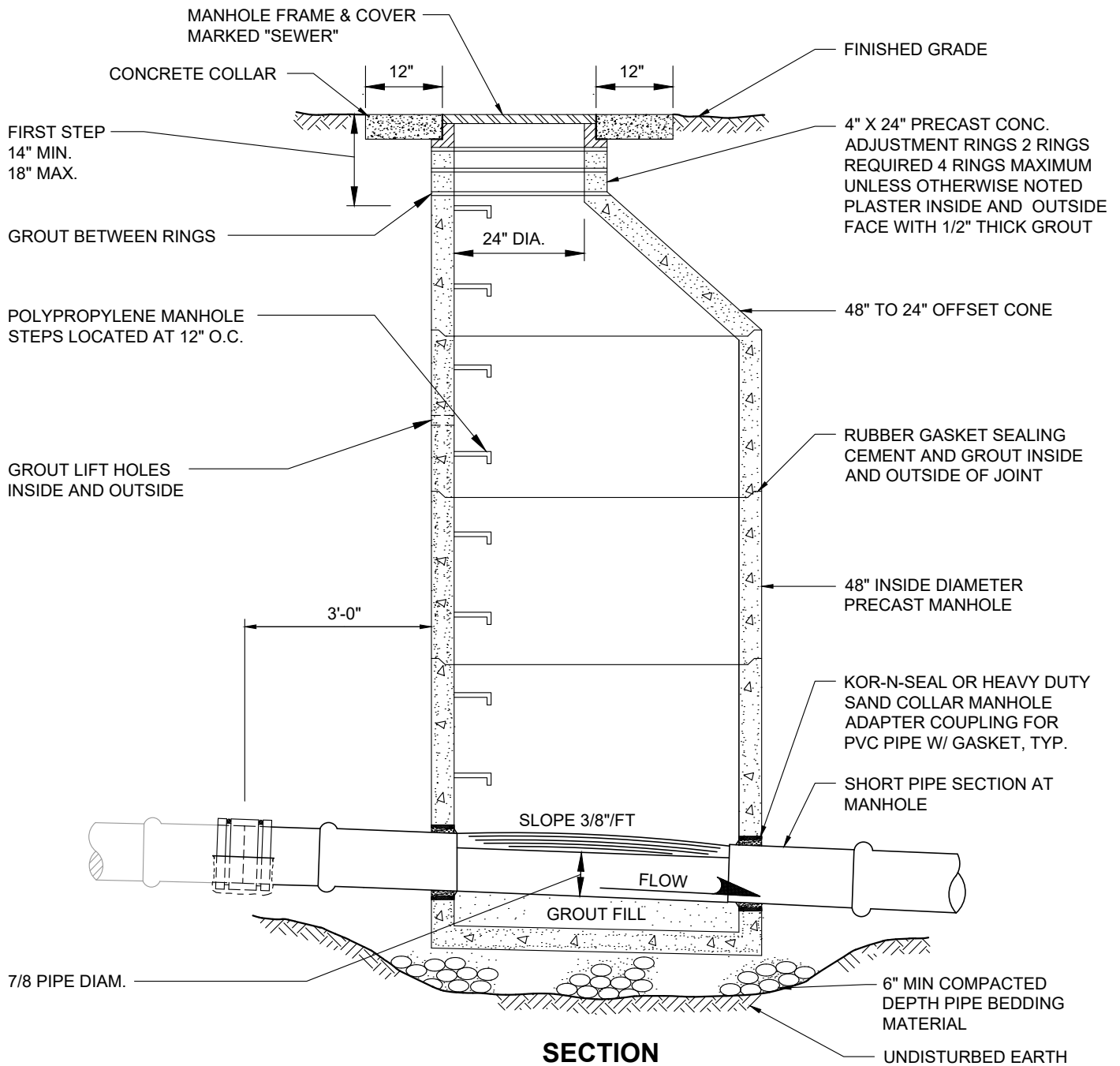

SECTION

NOTES

1. DROP OF GRADE THRU MANHOLE SHALL BE 0.10', UNLESS OTHERWISE NOTED.
2. MANHOLES SHALL BE SET PLUMB.
3. FOR CONNECTION OF EXISTING SEWER PIPE TO NEW MANHOLE, PROVIDE 3 LF OF PVC SEWER PIPE AND ROMAC 501 COUPLING, OR EQUAL.

M:\ROSLYN\23867 Construction Standards Update\Figures\SEWER\SS-2.dwg, 10/1/2024 10:51 AM, FRANK PARKER



CITY OF ROSLYN
 CONSTRUCTION STANDARDS
DETAIL SS-2
STANDARD 48" MANHOLE

Gray & Osborne, Inc.
 CONSULTING ENGINEERS

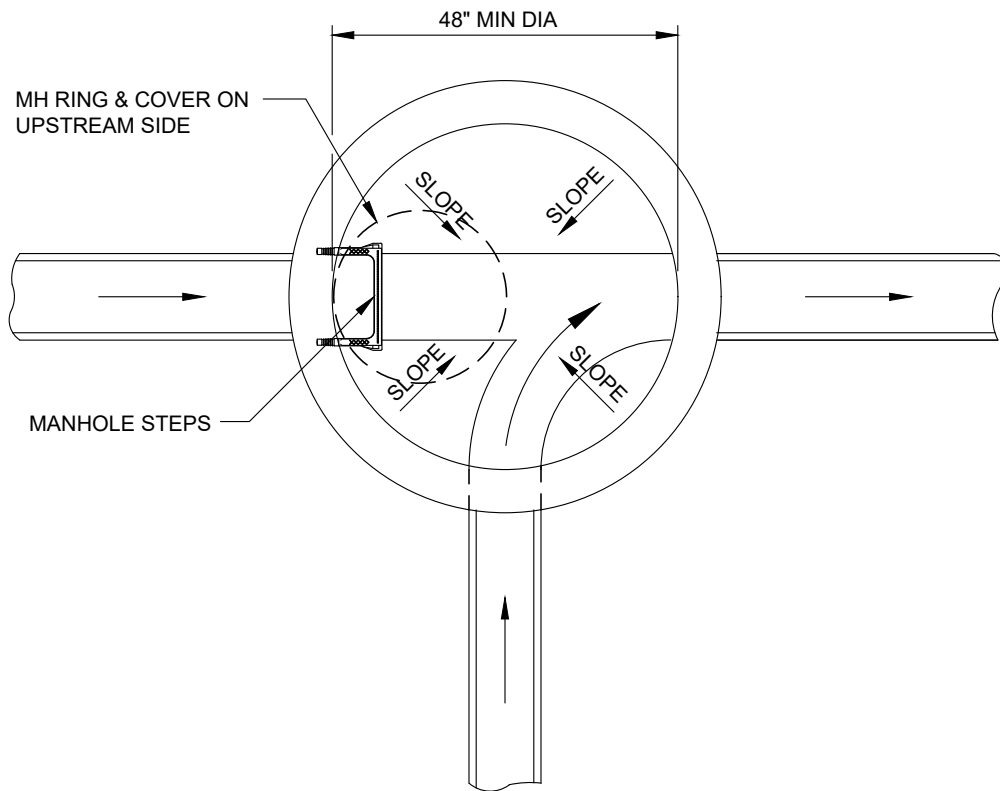

NOTE:

TRANSITION FROM MANHOLE BENCH TO CHANNEL SHALL BE ROUNDED WITH NO SHARP EDGES. PIPE PENETRATIONS AND CHANNELS SHALL PROVIDE A SMOOTH SURFACE THAT SHALL NOT RETAIN ANY WATER.

M:\ROS\LYN\23867 Construction Standards Update\Figures\SEWER\SS-3.dwg, 10/1/2024 10:51 AM, FRANK PARKER



CITY OF ROSLYN
CONSTRUCTION STANDARDS

DETAIL SS-3
MANHOLE PLAN VIEW



STANDARD CI MANHOLE RING & COVER - GROUT TO PRECAST CONCRETE MANHOLE RINGS

SET TOP FLUSH WITH FINISHED GRADE

2'-0" MIN OPENING

12"

PRECAST CONC MH RINGS FOR FUTURE GRADE ADJUSTMENT
- 4" MIN
- 6" MAX

54" TO 24" PRECAST ECCENTRIC CONE

14" STEPS 12" OC SEE DETAIL.

3'-0" MIN.

CUT OUT EXISTING CONC PIPE, MAKE SMOOTH INVERT & CHANNEL

54" DIAM.

PRECAST CONC MH SECTIONS

CAST IN PLACE CHANNEL & SHELF, 4000 PSI CONCRETE

1'-0"

NEW PVC SEWER MAIN

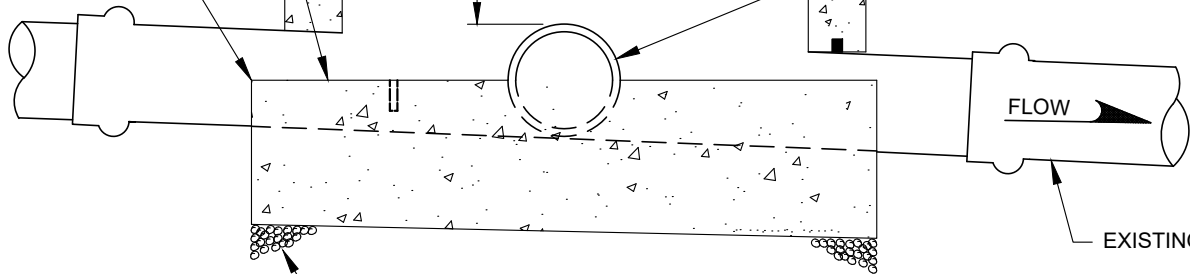

BEDDING OR FOUNDATION GRAVEL AS APPROVED

M:\ROSLYN\23867 Construction Standards Update\Figures\SEWERSS-4.dwg, 10/1/2024 10:51 AM, FRANK PARKER



CITY OF ROSLYN
CONSTRUCTION STANDARDS

DETAIL SS-4
SADDLE MANHOLE



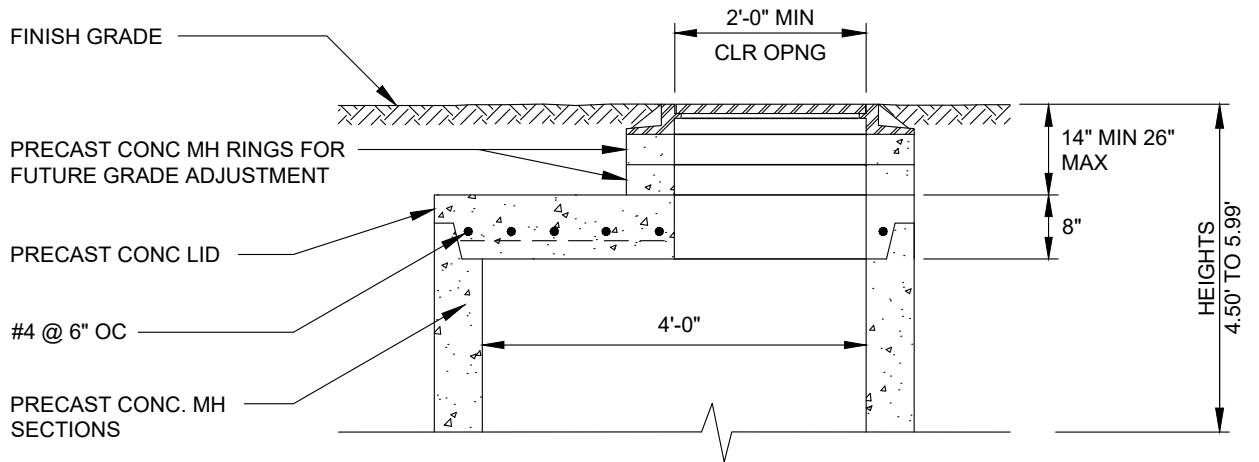

NOTE:

DETAILS OF MH BASE, WALL SECTIONS & STEPS IDENTICAL W/STANDARD MANHOLE DETAILS.

M:\ROSLYN\23867 Construction Standards Update\Figures\SEWER\SS-5.dwg, 10/1/2024 10:51 AM, FRANK PARKER



CITY OF ROSLYN
CONSTRUCTION STANDARDS
DETAIL SS-5
SHALLOW MANHOLE



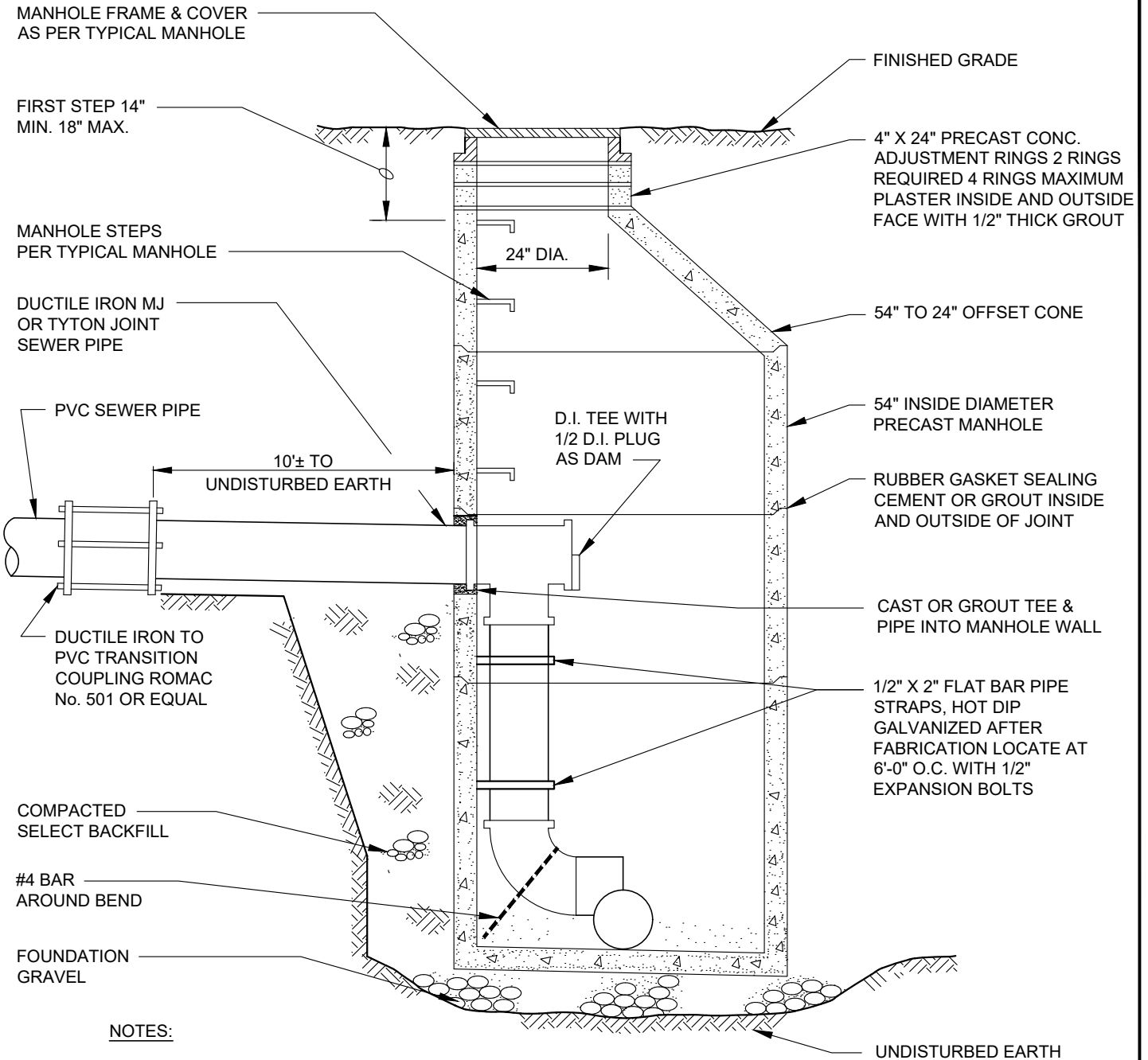

NOTES:

1. PIPE CONNECTIONS TO MANHOLES SHALL BE AS FOLLOWS:
 PVC PIPE: CAST OR GROUT A MANHOLE COUPLING INTO WALL. D.I. PIPE: BELL AND SPIGOT JOINT OR FLEXIBLE COUPLING EITHER SHALL BE 12" MAXIMUM DISTANCE FROM MANHOLE WALL. PVC AND D.I. PIPE, OPTIONAL: CORE THE MANHOLE AND CONNECT SEWER PIPE WITH A WATER TIGHT FLEXIBLE RUBBER BOOT IN MANHOLE WALL, KOR-N-SEAL BOOT OR EQUAL.
2. DROP OF GRADE THRU MANHOLE SHALL BE 0.10', UNLESS OTHERWISE NOTED.

M:\ROSLYN\23867 Construction Standards Update\Figures\SEWER\SS-6.dwg, 10/1/2024 10:51 AM, FRANK PARKER



CITY OF ROSLYN
 CONSTRUCTION STANDARDS
DETAIL SS-6
DROP MANHOLE CONNECTION

Gray & Osborne, Inc.
 CONSULTING ENGINEERS

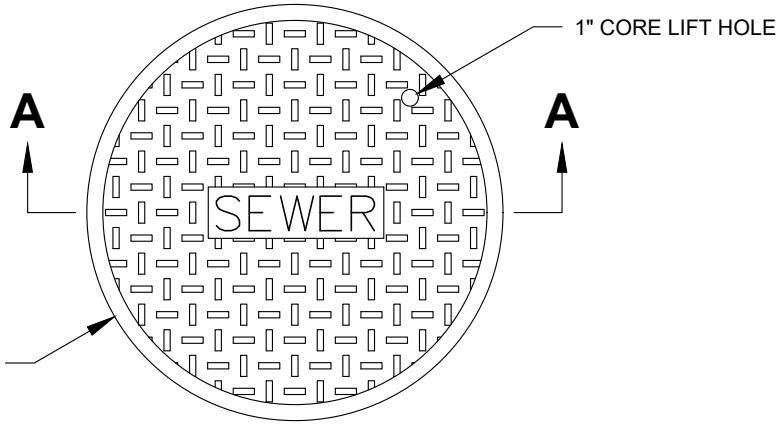

"SEWER" CAST ON COVER WITH 3" HIGH RAISED LETTERS (NON-SKID PATTERN) AS MANUFACTURED BY "SATHER MANUFACTURING CO., INC." NO. 6024-R.

PLAN

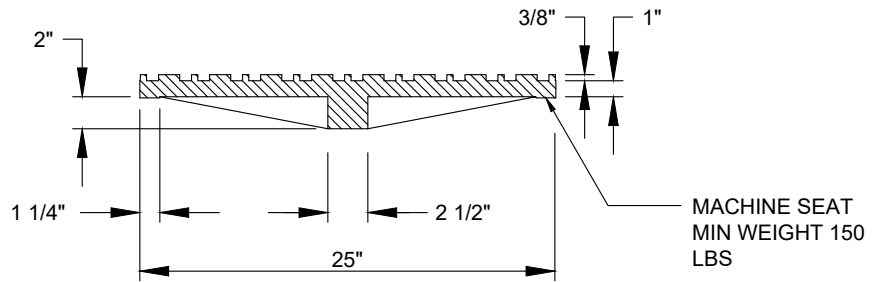

SECTION A-A

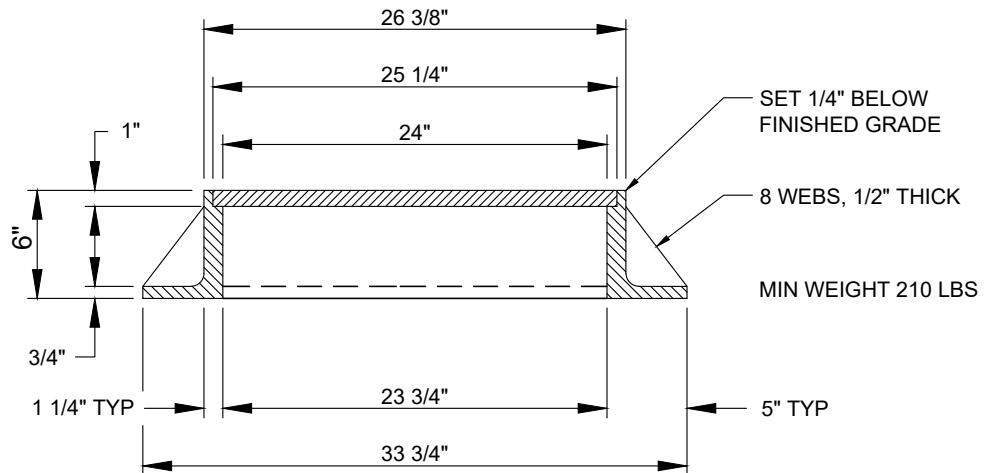

NOTE:

FRAME AND COVER SHALL BE H-20 RATED.

M:\ROSLYN\23867 Construction Standards Update\Figures\SEWER\SS-7.dwg, 10/1/2024 10:51 AM, FRANK PARKER



CITY OF ROSLYN
CONSTRUCTION STANDARDS
DETAIL SS-7
STANDARD MANHOLE FRAME
AND COVER



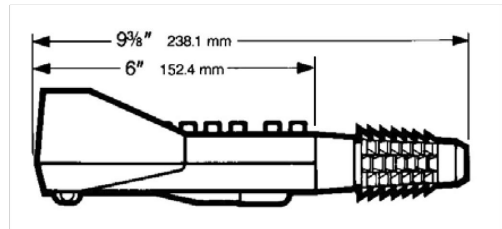
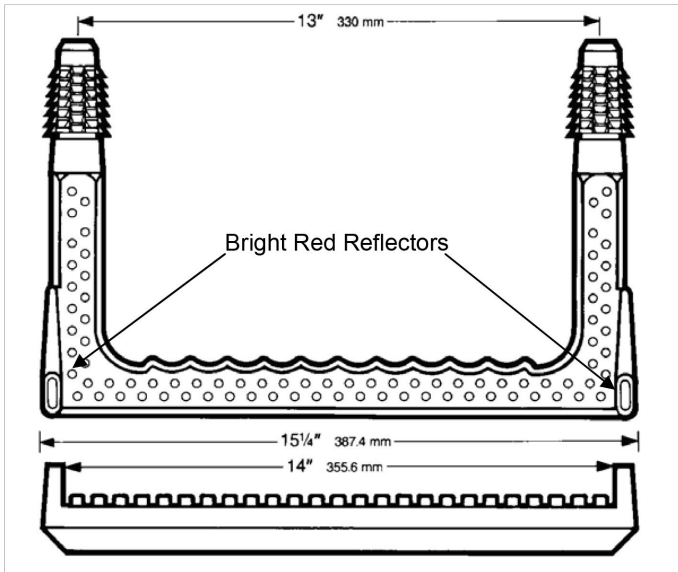

SPECIFICATIONS

All Lane Poly Steps meet the requirements of ASTM C-478 and AASHTO M-199. The polypropylene conforms to ASTM D-4101. The 1/2" Grade 60 reinforcing bar meets ASTM A-615.

NOTE:

MANHOLE STEP MUST BE LANE P-14938 STEP OR APPROVED EQUAL.

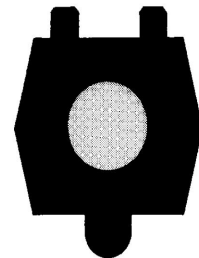

RUNG

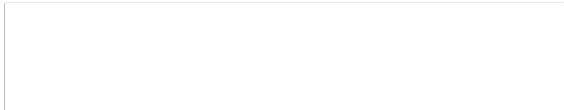

CITY OF ROSLYN
CONSTRUCTION STANDARDS

DETAIL SS-8
MANHOLE STEP



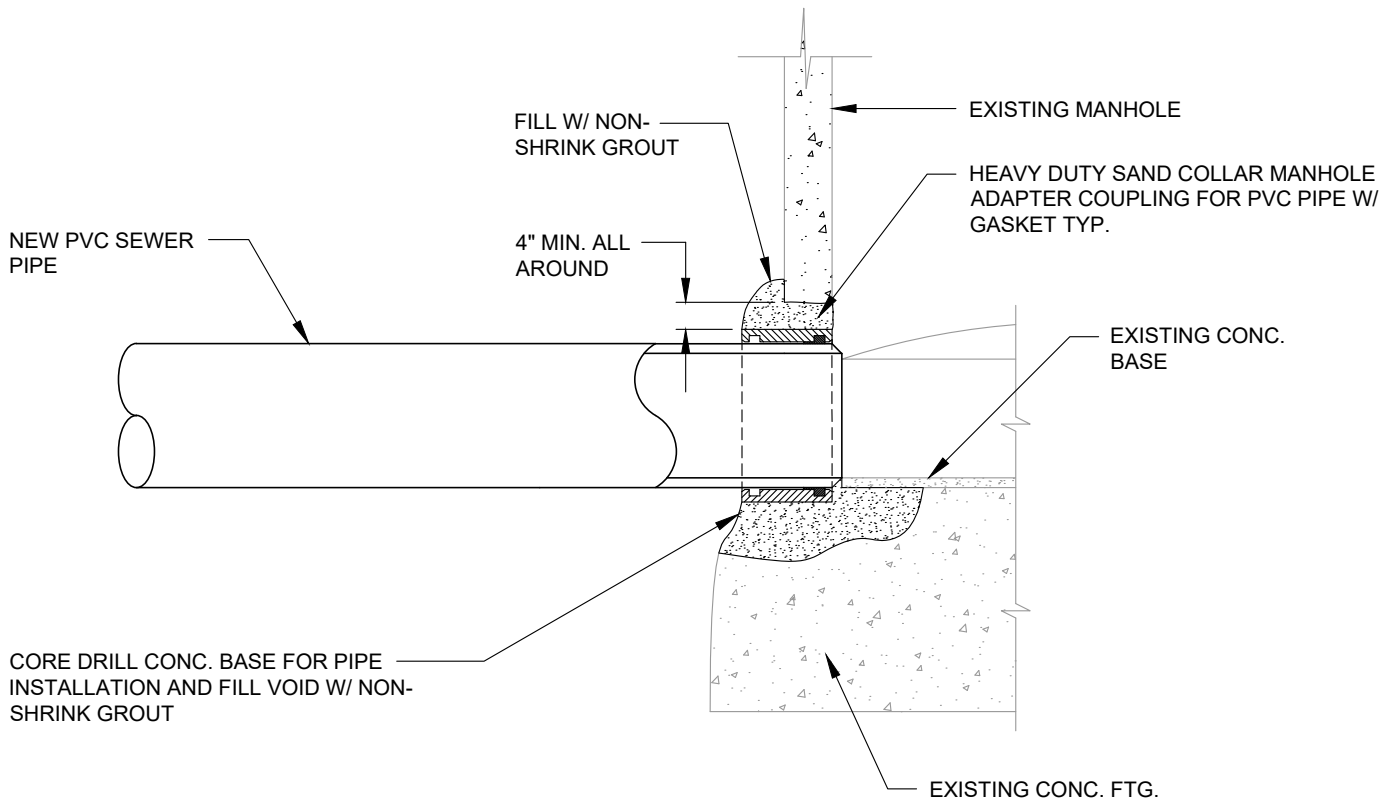

CITY OF ROSLYN
CONSTRUCTION STANDARDS
DETAIL SS-9
**CONNECTION TO EXISTING
SANITARY SEWER MANHOLE**



Gray & Osborne, Inc.
CONSULTING ENGINEERS

SEWER MAIN

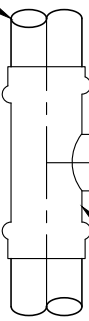

6" TEE ON SEWER MAIN

6" SIDE SEWER

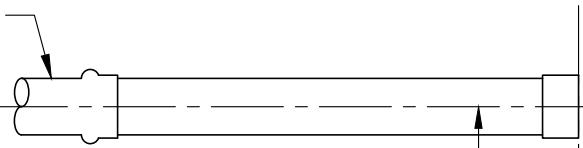

PROPERTY LINE

10' MIN.

PLAN

NOTES:

1. MAXIMUM DEFLECTION NOT TO EXCEED PIPE MANUFACTURER RECOMMENDATIONS.
2. SIDE SEWER LATERAL SHALL BE THE SAME MATERIAL AS THE MAIN LINE SEWER AND BEDDED THE SAME.
3. SEPARATE LATERAL REQUIRED FOR EACH LOT.

SEE CLEANOUT DETAIL

FINISHED GRADE

PROPERTY LINE

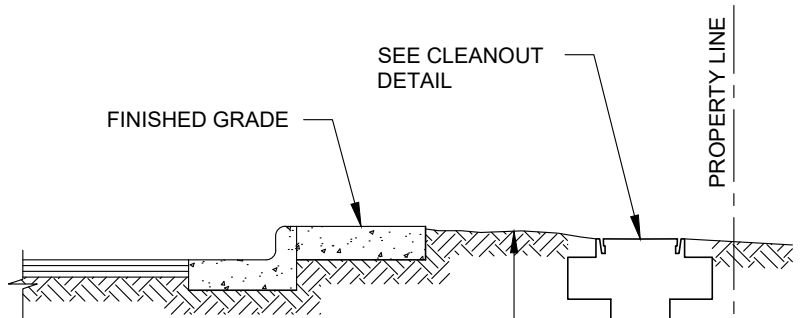

4'-0" MINIMUM

VARIES

6" SIDE SEWER

FITTINGS AS REQUIRED

6" TEE ON SEWER MAIN OR ROMAC CB SEWER SADDLE

SEWER MAIN

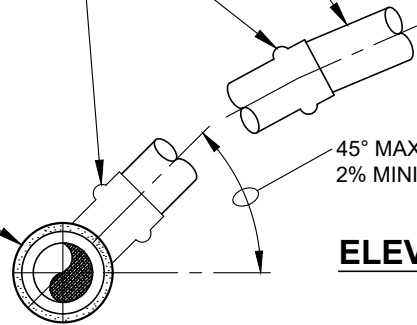

45° MAXIMUM SLOPE
2% MINIMUM SLOPE

ELEVATION

WATERTIGHT CAP
D.I.: MJ CAP
PVC: GASKETED CAP

M:\ROSLYN\23867 Construction Standards Update\Figures\SEWERS\SS-10.dwg, 10/1/2024 10:52 AM, FRANK PARKER



CITY OF ROSLYN
 CONSTRUCTION STANDARDS
DETAIL SS-10
STANDARD SIDE SEWER



CLEANCHECK
BACKWATER
VALVE WITH
RISER PIPE AND
THREADED CAP

2' TO 6'

SIDE OF BUILDING

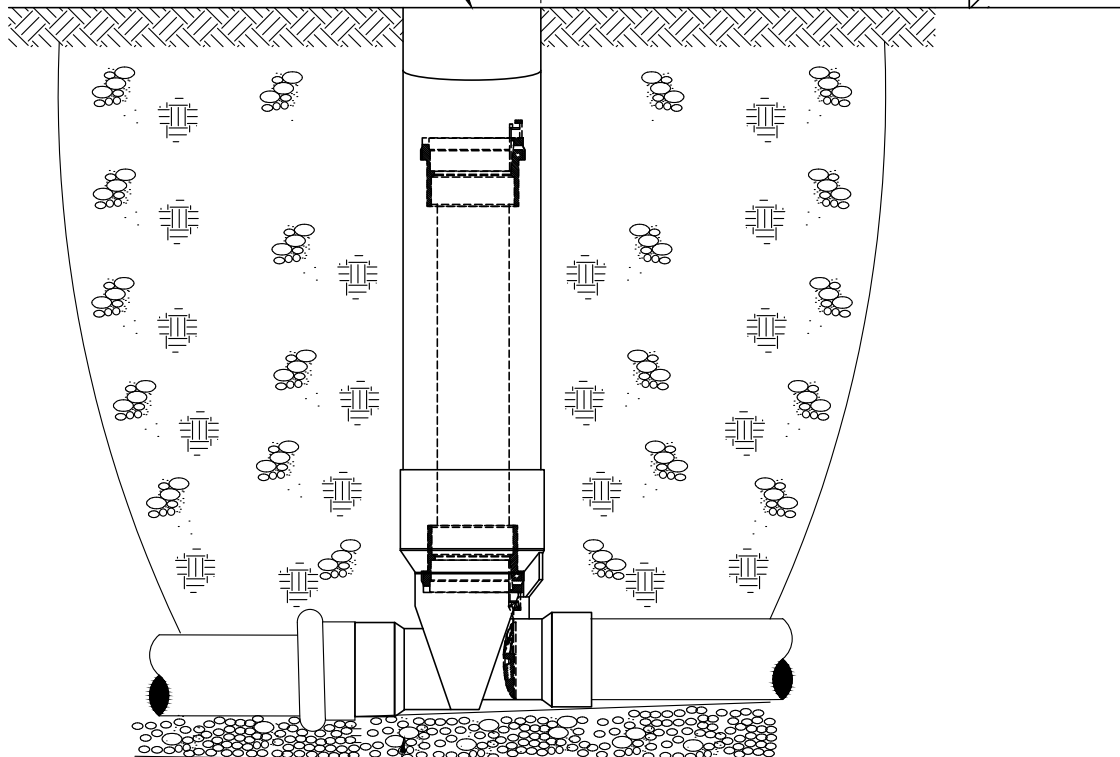

GRAVEL BACKFILL
FOR PIPE BEDDING

BUILDING SIDE SEWER CLEANOUT

NTS

M:\ROSLYN\23867 Construction Standards Update\Figures\SEWER\SS-11.dwg, 10/1/2024 10:52 AM, FRANK PARKER



CITY OF ROSLYN
CONSTRUCTION STANDARDS
DETAIL SS-11
**BUILDING SIDE SEWER
CLEANOUT**

Gray & Osborne, Inc.
CONSULTING ENGINEERS

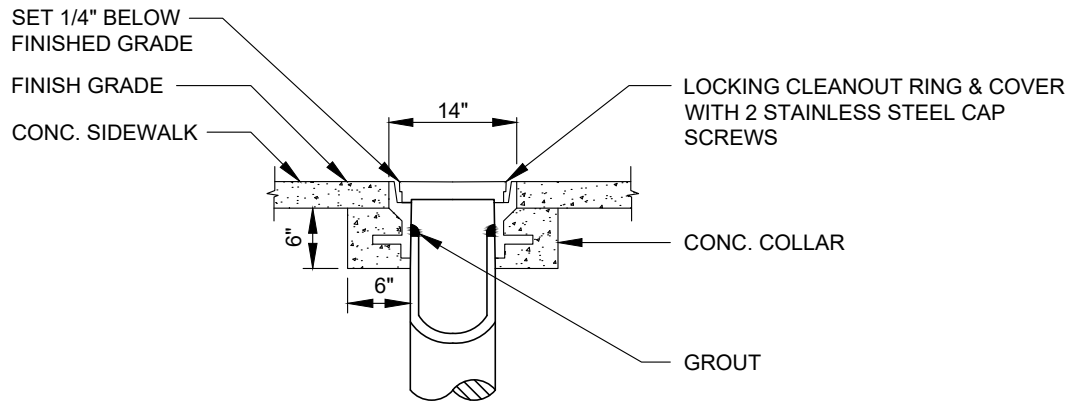

STREET USE

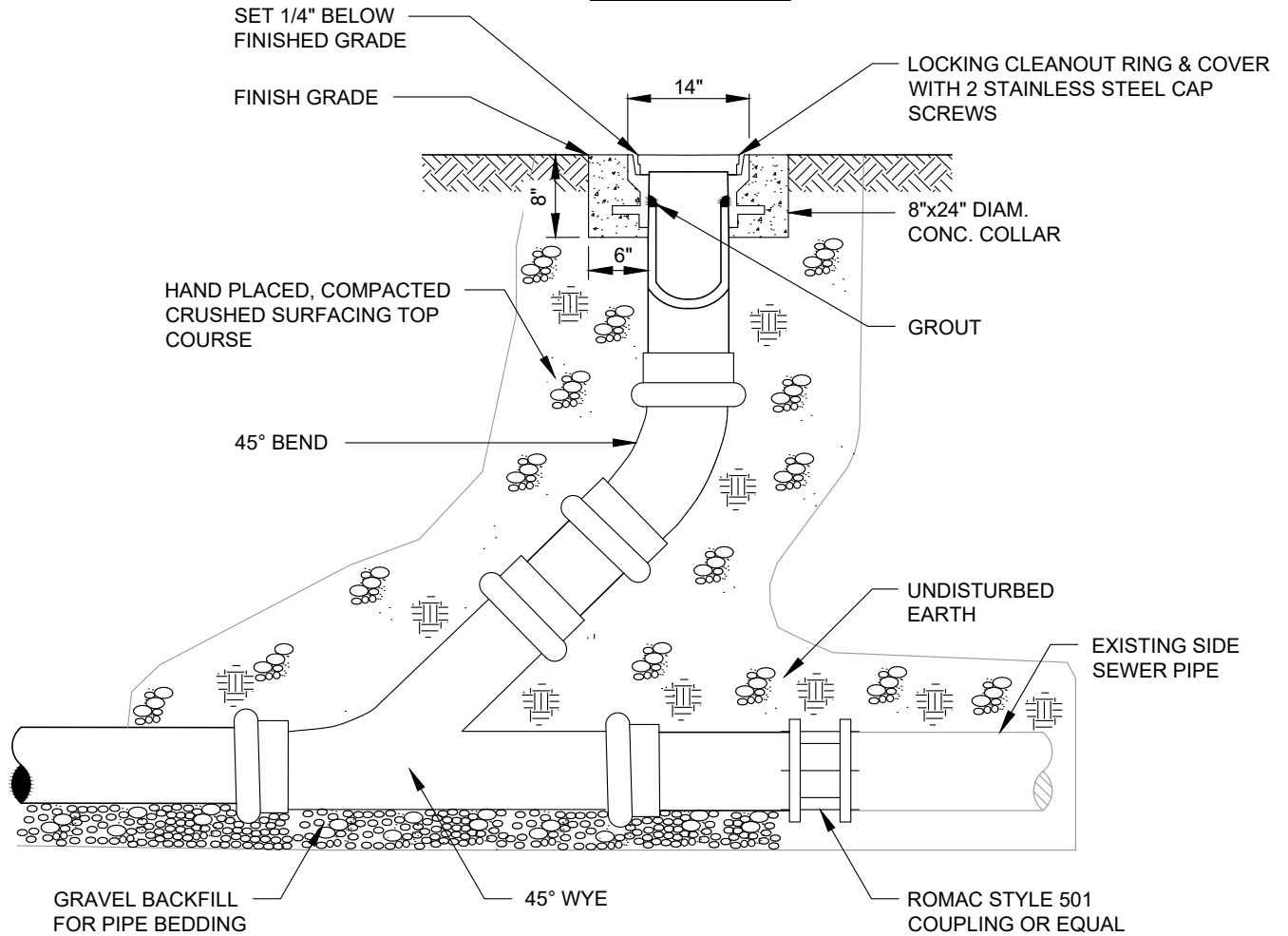

EASEMENT USE

M:\ROSLYN\23867 Construction Standards Update\Figures\SEWER\SS-12.dwg, 10/1/2024 10:52 AM, FRANK PARKER



CITY OF ROSLYN
 CONSTRUCTION STANDARDS
DETAIL SS-12
SANITARY SEWER CLEANOUT



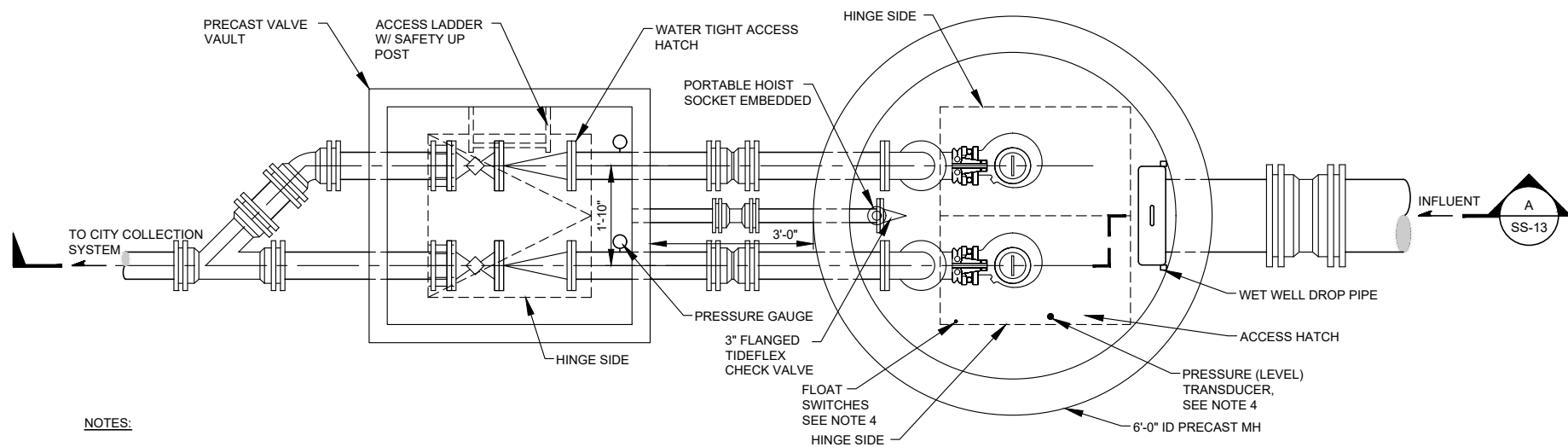

NOTES:

1. PUMP STATION SHOWN IS A GENERAL ARRANGEMENT DRAWING. EACH DEVELOPER PUMP STATION SHALL BE REVIEWED ON A CASE BY CASE BASIS AND MODIFIED TO MEET THE NEEDS OF THE DEVELOPMENT AND THE CITY.
2. PUMP STATION SHALL BE DESIGNED IN ACCORDANCE WITH CURRENT DEPARTMENT OF ECOLOGY CRITERIA FOR SEWAGE WORKS DESIGN.
3. CONTRACTOR SHALL COORDINATE THE LOCATION OF THE HOIST SOCKET WITH THE SPECIFIC PUMP SELECTED FOR THE PROJECT. HOIST SHALL BE LOCATED SUCH THAT THE HOOK IS DIRECTLY CENTERED ON THE LIFTING POINT OF THE PUMP.
4. TELEMETRY AND CONTROLS SHALL BE PROVIDED IN ACCORDANCE WITH THE CITY'S LATEST STANDARDS.



CITY OF ROSLYN
 CONSTRUCTION STANDARDS
DETAIL SS-13
COLLECTION SYSTEM
PUMP STATION

Gray & Osborne, Inc.
 CONSULTING ENGINEERS

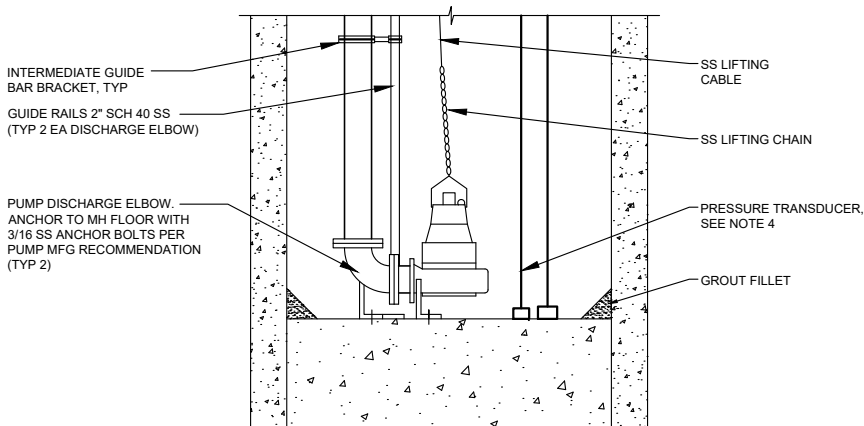
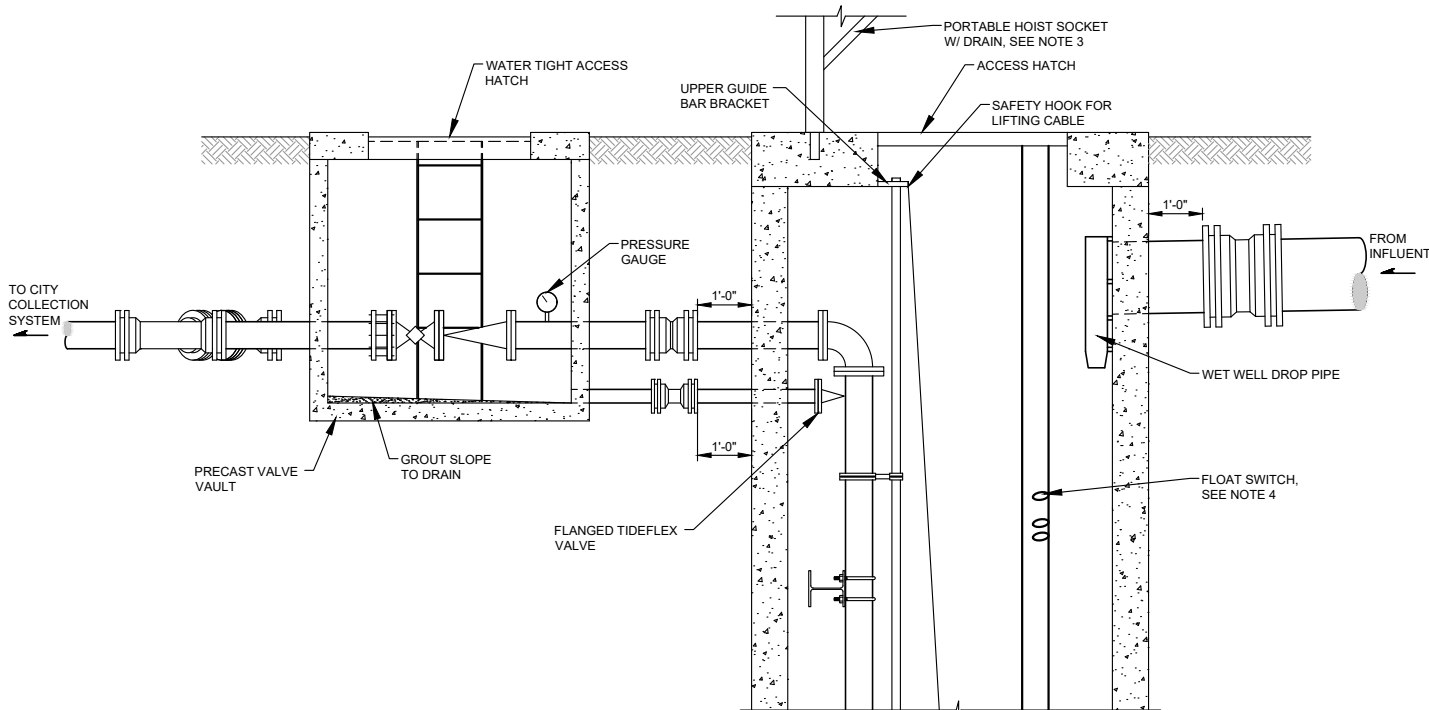

NOTES:

1. PUMP STATION SHOWN IS A GENERAL ARRANGEMENT DRAWING. EACH DEVELOPER PUMP STATION SHALL BE REVIEWED ON A CASE BY CASE BASIS AND MODIFIED TO MEET THE NEEDS OF THE DEVELOPMENT AND THE CITY.
2. PUMP STATION SHALL BE DESIGNED IN ACCORDANCE WITH CURRENT DEPARTMENT OF ECOLOGY CRITERIA FOR SEWAGE WORKS DESIGN.
3. CONTRACTOR SHALL COORDINATE THE LOCATION OF THE HOIST SOCKET WITH THE SPECIFIC PUMP SELECTED FOR THE PROJECT. HOIST SHALL BE LOCATED SUCH THAT THE HOOK IS DIRECTLY CENTERED ON THE LIFTING POINT OF THE PUMP.
4. TELEMETRY AND CONTROLS SHALL BE PROVIDED IN ACCORDANCE WITH THE CITY'S LATEST STANDARDS.

M:\ROSLYN\23867 Construction Standards Update\Figures\SEWERS\SS-14.dwg, 10/1/2024 10:53 AM, FRANK PARKER



CITY OF ROSLYN
CONSTRUCTION STANDARDS
DETAIL SS-14
COLLECTION SYSTEM
PUMP STATION SECTION



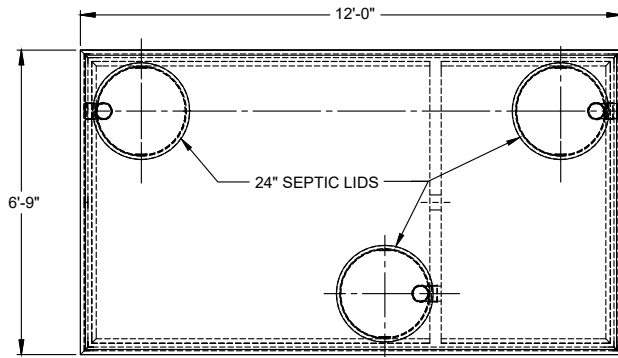

CONCRETE:
TANK CONSTRUCTION UTILIZES 4000 PSI
CONCRETE AND GRADE 60 REBAR.

REINFORCEMENT:
#4 BARS @ 6" OC EA WAY U-BARS IN TOP
(2) - #4 EACH SIDE OF ACCESS
#4 BARS @ 6" OC EA WAY IN SIDES
#4 BARS @ 6" OC EA WAY U-BARS IN BOTTOM

RISERS:
PVC: Ø24" & FIBER COVER (TO GRADE)
CONCRETE: Ø24" x 8" OR 12" (6" BELOW GRADE)

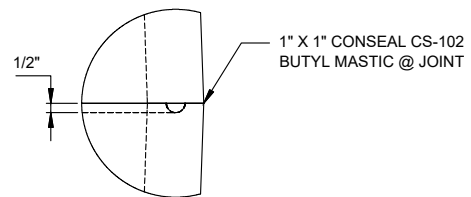
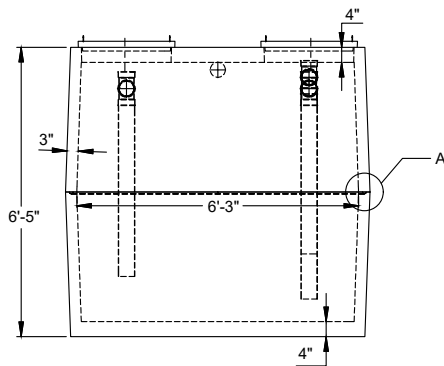
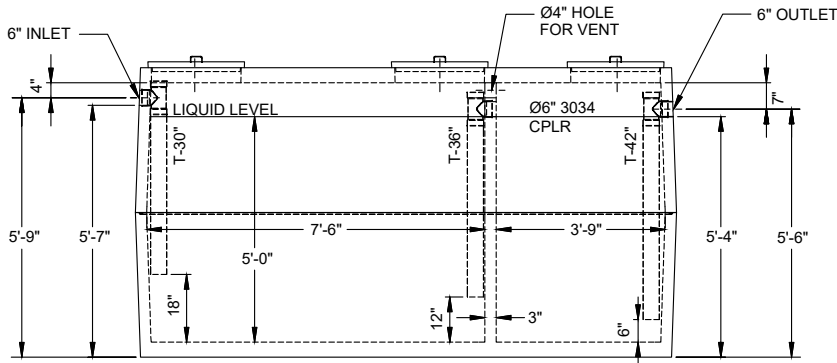

JOINT DETAIL A

NOTES:

1. GREASE INTERCEPTOR SIZE SHALL BE COORDINATED WITH AND APPROVED BY THE CITY.
2. GREASE INTERCEPTOR, LIDS, FRAMES, AND ADJUSTMENT RINGS SHALL BE H-20 RATED IN TRAFFIC AREAS OR WHERE OTHERWISE REQUIRED BY THE CITY.

M:\ROSLYN\23867 Construction Standards Update\Figures\SEWERSS-15.dwg, 10/1/2024 10:53 AM, FRANK PARKER



CITY OF ROSLYN
CONSTRUCTION STANDARDS
DETAIL SS-15
GREASE INTERCEPTOR



STREET DETAILS

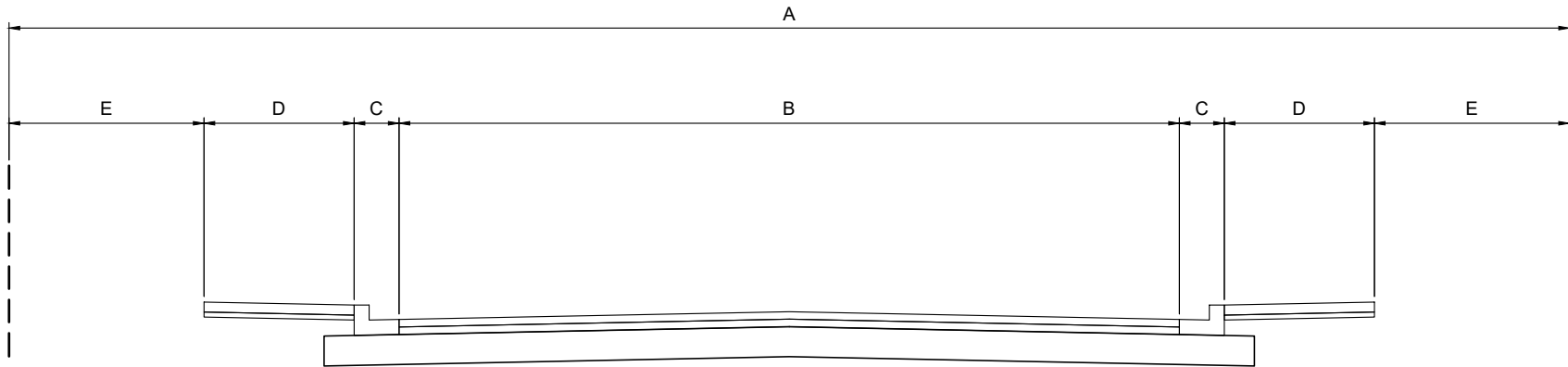

TYPICAL STREET SECTION TABLE

STREET CLASSIFICATION & ZONING (IF APPLICABLE)	A RIGHT-OF-WAY WIDTH	B PAVEMENT WIDTH (GUTTER LIP TO GUTTER LIP)	C CURB AND GUTTER TYPE (& WIDTH)	D SIDEWALK WIDTH	E UTILITY CORRIDOR / BUFFER
PRINCIPAL ARTERIAL STREET: COMMERCIAL AND/OR INDUSTRIAL ZONING DISTRICTS	80'	52'	VERTICAL (1.5') BOTH SIDES	10' BOTH SIDES	2.5' BOTH SIDES
MINOR ARTERIAL STREET: RESIDENTIAL ZONING DISTRICTS	70'	30'	VERTICAL (1.5') BOTH SIDES	6' BOTH SIDES	12.5' BOTH SIDES
MAJOR COLLECTOR STREET	60'	30'	VERTICAL (1.5') BOTH SIDES	6' BOTH SIDES	7.5' BOTH SIDES
MINOR COLLECTOR STREET	60'	20'	VERTICAL (1.5') BOTH SIDES	5' BOTH SIDES	13.5' BOTH SIDES
LOCAL ACCESS STREET	60'	20'	NONE	5' WHERE DESIGNATED BY CITY	VARIES

NOTES:

- ROADWAY SECTION DEPTHS MUST BE DETERMINED FROM A GEOTECHNICAL INVESTIGATION PERFORMED BY A LICENSED GEOTECHNICAL ENGINEER.
- SIDEWALKS WILL BE REQUIRED WHERE EXTENDING CITY DESIGNATED WALKING ROUTES AND WHERE REQUIRED BY CITY TO SERVE PROPOSED PEDESTRIAN GENERATORS, OR AS OTHERWISE REQUIRED BY THE CITY PLANNER/PUBLIC WORKS DIRECTOR.



**CITY OF ROSLYN
CONSTRUCTION STANDARDS
DETAIL ST-1
TYPICAL ROADWAY SECTION**



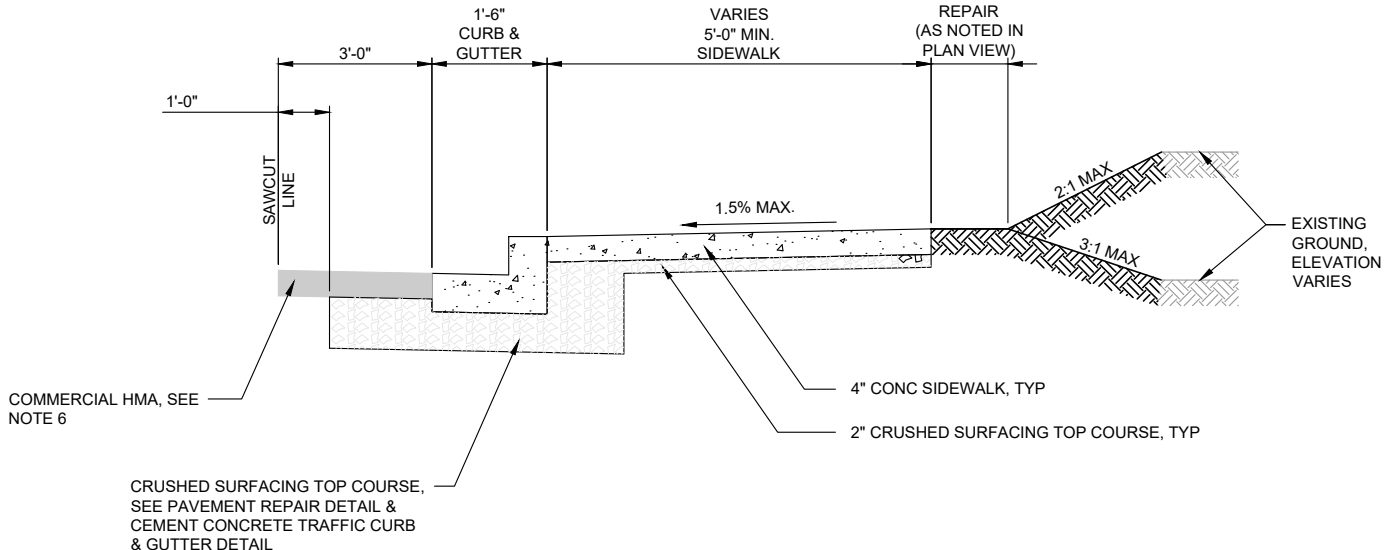

CRUSHED SURFACING TOP COURSE, SEE PAVEMENT REPAIR DETAIL & CEMENT CONCRETE TRAFFIC CURB & GUTTER DETAIL

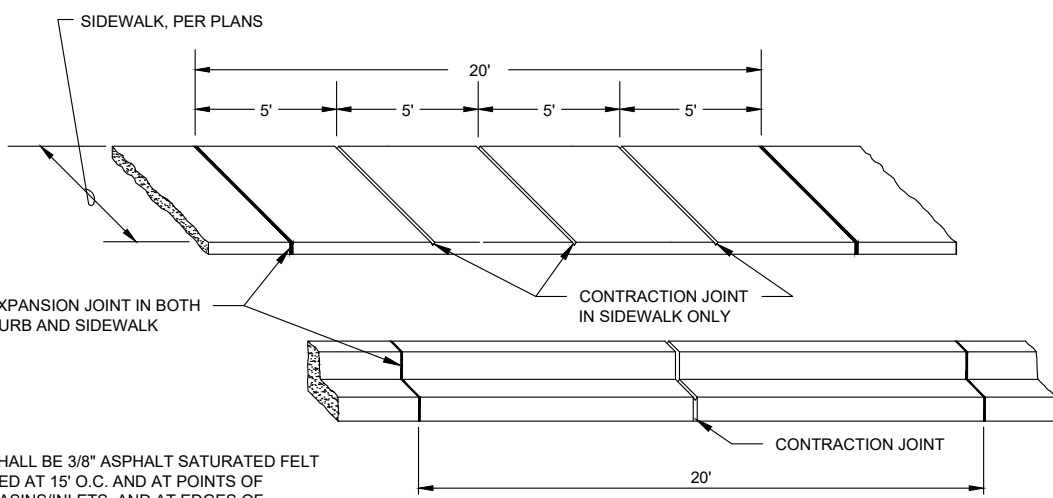

NOTES:

1. EXPANSION/CONTRACTION JOINTS SHALL BE 3/8" ASPHALT SATURATED FELT TO FULL DEPTH OF CONCRETE PLACED AT 15' O.C. AND AT POINTS OF TANGENCY ON CURVES, AT CATCH BASINS/INLETS, AND AT EDGES OF ALLEYS, DRIVEWAYS, AND CURB RAMPS.
2. V-GROOVE MARKS SHALL BE 1/8" DEEP AND 1/4" WIDE PLACED AT 5' OC FOR 5' SIDEWALKS.
3. ALL JOINTS SHALL BE CLEAN AND EDGED TO A 1/4" RADIUS. JOINTS SHALL BE FLUSH WITH THE FINISHED SURFACE.
4. SIDEWALK SHALL CONSIST OF 4" DEPTH CEMENT CONC. PLACED ON 4" COMPACTED DEPTH CRUSHED SURFACING TOP COURSE.
5. SIDEWALK SHALL MEET ADA REQUIREMENTS AND SHALL HAVE NO LESS THAN FOUR FEET OF WIDTH AS A MINIMUM PEDESTRIAN ACCESSIBLE ROUTE FREE OF VERTICAL AND HORIZONTAL OBSTRUCTIONS. GRATINGS, ACCESS COVERS, JUNCTION BOXES, CABLE VAULTS, PULL BOXES AND OTHER APPURTENANCES WITHIN THE SIDEWALK MUST HAVE SLIP RESISTANT SURFACES, BE FLUSH WITH SURFACE, AND MATCH GRADE OF THE SIDEWALK.
6. COMMERCIAL HMA PER TYPICAL ROADWAY SECTION FOR NEW CONSTRUCTION OR COMMERCIAL HMA PER TRENCH PATCH DETAIL IF ADDING SIDEWALK TO AN EXISTING ROADWAY.

M:\ROSLYN\23867 Construction Standards Update\Figures\STREET\ST-2.dwg, 10/12/2024 11:56 AM, FRANK PARKER



CITY OF ROSLYN

CONSTRUCTION STANDARDS

DETAIL ST-2

TYPICAL CONCRETE SIDEWALK



Gray & Osborne, Inc.
CONSULTING ENGINEERS

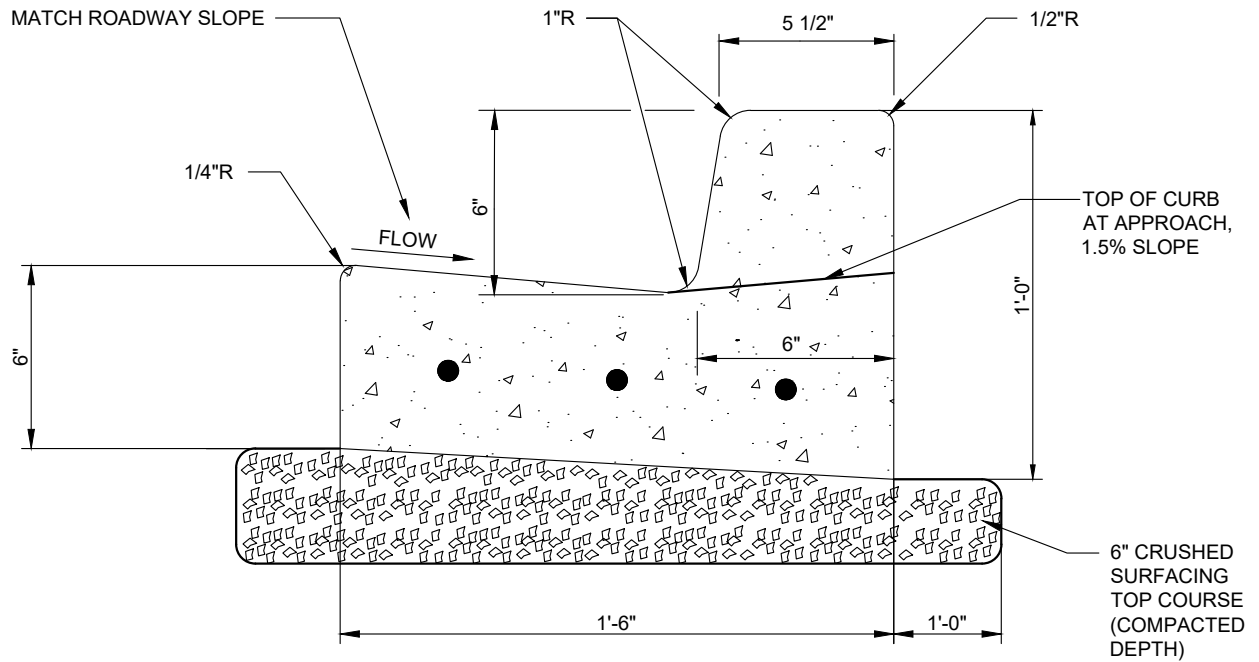

NOTES:

1. EXPANSION JOINT MATERIAL SHALL BE 3/8" THICK PREMOLDED JOINT FILLER FULL THICKNESS OF CONCRETE SPACING.
2. FORMS AND SUBGRADE INSPECTION AND APPROVAL BY THE CONTRACTING AGENCY REQUIRED PRIOR TO POURING CONCRETE.
3. THE TOP, FACE & GUTTER SHALL BE BROOM FINISHED PARALLEL TO THE ROADWAY.
4. 3 - #4 REBAR AT DRIVEWAYS AND DEPRESSIONS.

M:\ROS\YN\23867 Construction Standards Update\Figures\STREET\ST-3.dwg, 10/12/2024 11:56 AM, FRANK PARKER



CITY OF ROSLYN
CONSTRUCTION STANDARDS
DETAIL ST-3
TYPICAL CURB AND GUTTER



M:\ROSLYN\23867 Construction Standards Update\Figures\STREET\ST-4.dwg, 10/12/2024 11:56 AM, FRANK PARKER

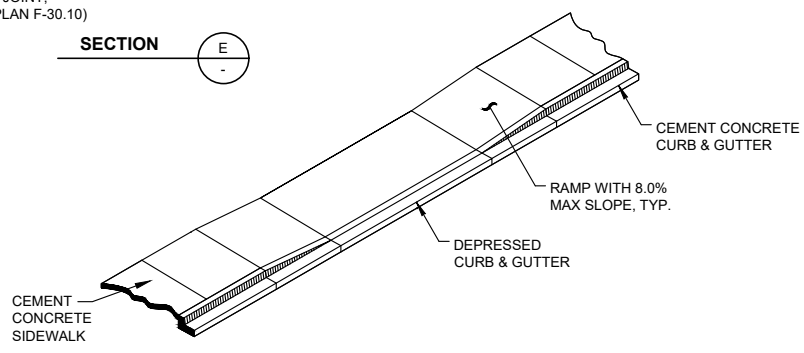
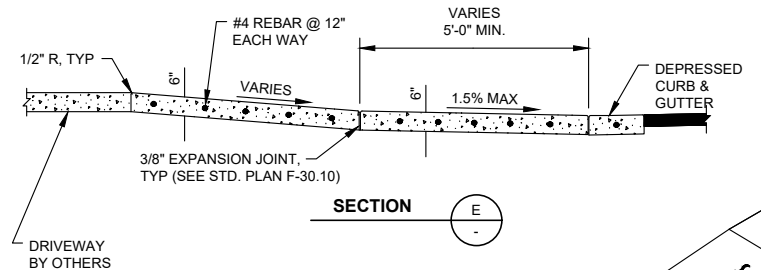
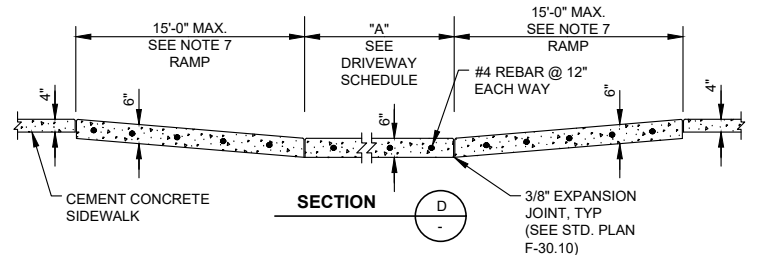
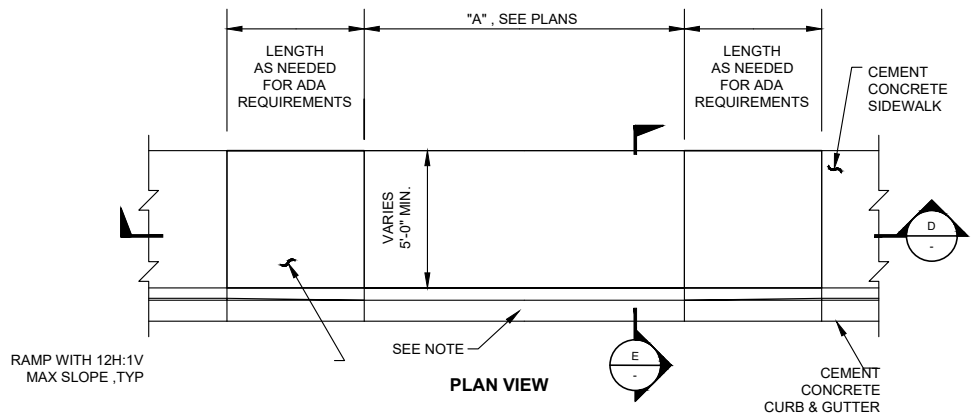

NOTES:

1. WHEN THE DRIVEWAY WIDTH EXCEEDS 10 FEET, CONSTRUCT A FULL DEPTH EXPANSION JOINT, SEE WSDOT STANDARD PLAN F-30.10 WITH 3/8" JOINT FILLER ALONG THE DRIVEWAY CENTERLINE. CONSTRUCT EXPANSION JOINTS PARALLEL WITH THE CENTERLINE AS REQUIRED AT 15' MAX SPACING WHEN DRIVEWAY WIDTHS EXCEED 30'.
2. COMPACT NATIVE MATERIAL TO 95% MAXIMUM DENSITY.
3. 6" CEMENT CONCRETE CLASS 4000.
4. 2" CRUSHED SURFACING TOP COURSE FOR BASE. CRUSHED SURFACING MATERIAL BENEATH CONCRETE DRIVEWAY NOT SHOWN FOR CLARITY.
5. CONCRETE DRIVEWAYS SHALL INCLUDE #4 REBAR AS SHOWN.
6. AVOID PLACING DRAINAGE STRUCTURES, JUNCTION BOXES OR OTHER OBSTRUCTIONS IN FRONT OF DRIVEWAY ENTRANCES.
7. THE CURB RAMP MAXIMUM RUNNING SLOPE SHALL NOT REQUIRE THE RAMP LENGTH TO EXCEED 15' (FT) TO AVOID CHASING THE SLOPE INDEFINITELY WHEN CONNECTING TO STEEP GRADES. WHEN APPLYING THE 15' (FT) MAX. LENGTH, THE RUNNING SLOPE OF THE CURB RAMP SHALL BE AS FLAT AS FEASIBLE.
8. RAMPS SHALL BE ADA COMPLIANT.

DRIVEWAY SEPARATION (MEASURED FROM BOTTOM OF THE TAPERS)

	PRIMARY ARTERIAL	MINOR ARTERIAL	MAJOR COLLECTOR	MINOR COLLECTOR	LOCAL ACCESS
DISTANCE FROM INTERSECTIONS	100 FEET	75 FEET	50 FEET	30 FEET	30 FEET
DISTANCE FROM INTERIOR LOT LINES	30 FEET	20 FEET	20 FEET	TAPER LENGTH	TAPER LENGTH
SEPARATION BETWEEN DRIVEWAYS ON ONE LOT	100 FEET	75 FEET	60 FEET	12 FEET	12 FEET

DRIVEWAY WIDTH
 SINGLE - 10 FEET MIN.
 DUPLEX - 30 FEET MAX.
 OTHER - 40 FEET MAX.



CITY OF ROSLYN
 CONSTRUCTION STANDARDS
DETAIL ST-4
CONCRETE DRIVEWAY ENTRANCE
OPTION A

Gray & Osborne, Inc.
 CONSULTING ENGINEERS

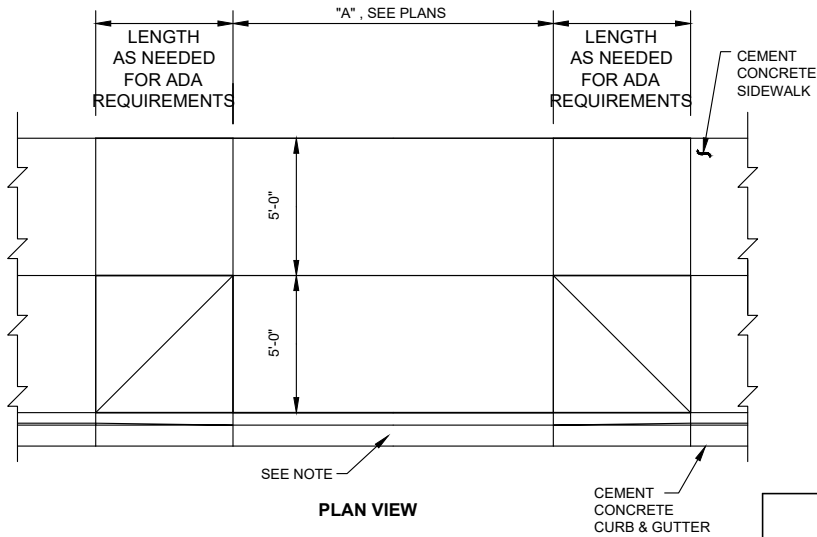

NOTES:

1. WHEN THE DRIVEWAY WIDTH EXCEEDS 10 FEET, CONSTRUCT A FULL DEPTH EXPANSION JOINT. SEE WSDOT STANDARD PLAN F-30.10 WITH 3/8" JOINT FILLER ALONG THE DRIVEWAY CENTERLINE. CONSTRUCT EXPANSION JOINTS PARALLEL WITH THE CENTERLINE AS REQUIRED AT 15' MAX SPACING WHEN DRIVEWAY WIDTHS EXCEED 30'.
2. COMPACT NATIVE MATERIAL TO 95% MAXIMUM DENSITY.
3. 6" CEMENT CONCRETE CLASS 4000.
4. 2" CRUSHED SURFACING TOP COURSE FOR BASE. CRUSHED SURFACING MATERIAL BENEATH CONCRETE DRIVEWAY NOT SHOWN FOR CLARITY.
5. CONCRETE DRIVEWAYS SHALL INCLUDE #4 REBAR AS SHOWN.
6. AVOID PLACING DRAINAGE STRUCTURES, JUNCTION BOXES OR OTHER OBSTRUCTIONS IN FRONT OF DRIVEWAY ENTRANCES.
7. THE CURB RAMP MAXIMUM RUNNING SLOPE SHALL NOT REQUIRE THE RAMP LENGTH TO EXCEED 15' (FT) TO AVOID CHASING THE SLOPE INDEFINITELY WHEN CONNECTING TO STEEP GRADES. WHEN APPLYING THE 15' (FT) MAX. LENGTH, THE RUNNING SLOPE OF THE CURB RAMP SHALL BE AS FLAT AS FEASIBLE.
8. RAMPS SHALL BE ADA COMPLIANT.

DRIVEWAY SEPARATION (MEASURED FROM BOTTOM OF THE TAPERS)

	PRIMARY ARTERIAL	MINOR ARTERIAL	MAJOR COLLECTOR	MINOR COLLECTOR	LOCAL ACCESS
DISTANCE FROM INTERSECTIONS	100 FEET	75 FEET	50 FEET	30 FEET	30 FEET
DISTANCE FROM INTERIOR LOT LINES	30 FEET	20 FEET	20 FEET	TAPER LENGTH	TAPER LENGTH
SEPARATION BETWEEN DRIVEWAYS ON ONE LOT	100 FEET	75 FEET	60 FEET	12 FEET	12 FEET

DRIVEWAY WIDTH
 SINGLE - 10 FEET MIN.
 DUPLEX - 30 FEET MAX.
 OTHER - 40 FEET MAX.

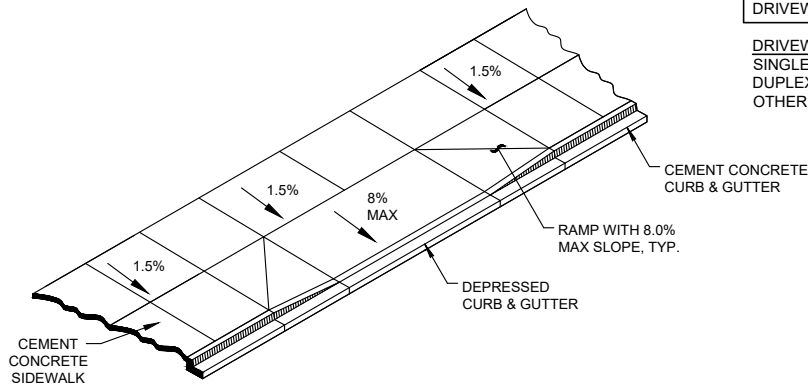

CITY OF ROSLYN
 CONSTRUCTION STANDARDS
DETAIL ST-5
CONCRETE DRIVEWAY ENTRANCE
OPTION B

Gray & Osborne, Inc.
 CONSULTING ENGINEERS



M:\ROSLYN\23867 Construction Standards Update\Figures\ST-6.dwg, 10/12/2024 11:57 AM, FRANK PARKER

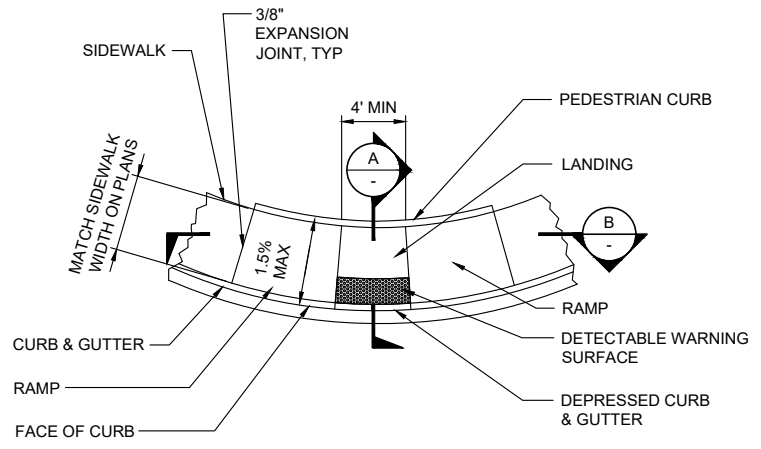
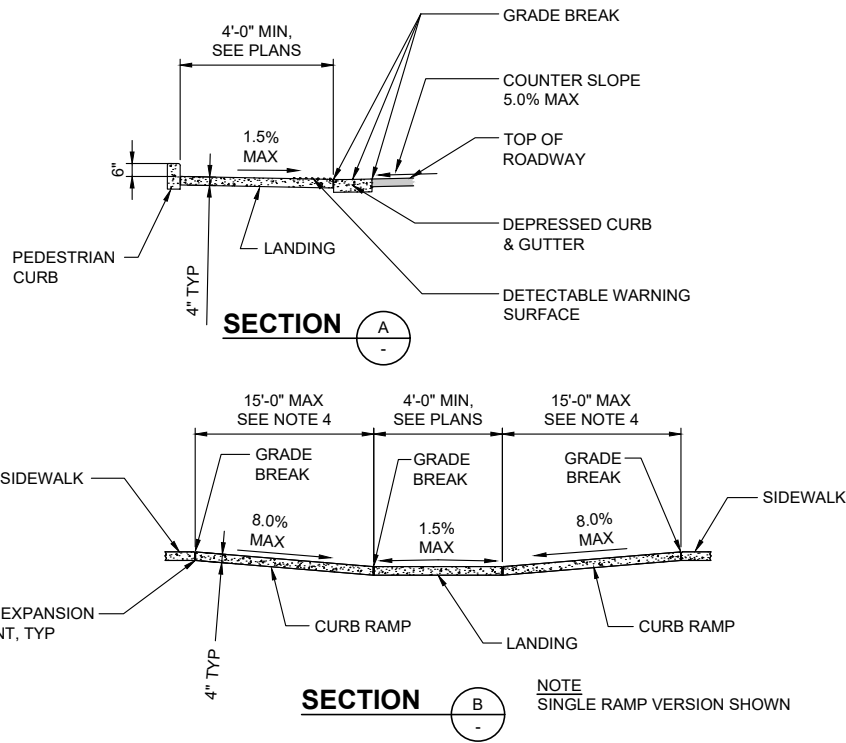

NOTES

1. PROVIDE A SEPARATE CURB RAMP FOR EACH MARKED OR UNMARKED CROSSWALK. CURB RAMP LOCATION SHALL BE PLACED WITHIN THE WIDTH OF THE ASSOCIATED CROSSWALK.
2. WHERE "GRADE BREAK" IS CALLED OUT, THE ENTIRE LENGTH OF THE GRADE BREAK BETWEEN THE TWO ADJACENT SURFACE PLANES SHALL BE FLUSH.
3. DO NOT PLACE GRATINGS, JUNCTION BOXES, ACCESS COVERS, OR OTHER APPURTENANCES IN FRONT OF THE CURB RAMP OR ON ANY PART OF THE CURB RAMP OR LANDING.
4. THE CURB RAMP MAXIMUM RUNNING SLOPE SHALL NOT REQUIRE THE RAMP LENGTH TO EXCEED 15 FEET TO AVOID CHASING THE SLOPE INDEFINITELY WHEN CONNECTING TO STEEP GRADES. WHEN APPLYING THE 15 FOOT MAX LENGTH, THE RUNNING SLOPE OF THE CURB RAMP SHALL BE AS FLAT AS FEASIBLE.
5. CURB RAMP, LANDING, & FLARES SHALL RECEIVE BROOM FINISH.
6. DETECTABLE WARNING SURFACE SHALL MEET REQUIREMENTS OF WSDOT STANDARD DETAIL F45.10-02.



CITY OF ROSLYN
 CONSTRUCTION STANDARDS
DETAIL ST-6
PARALLEL SIDEWALK RAMP

Gray & Osborne, Inc.
 CONSULTING ENGINEERS

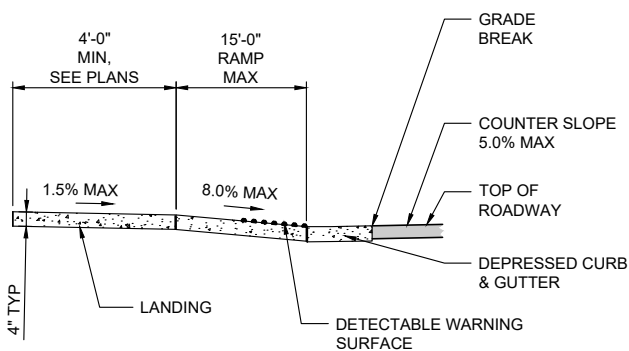
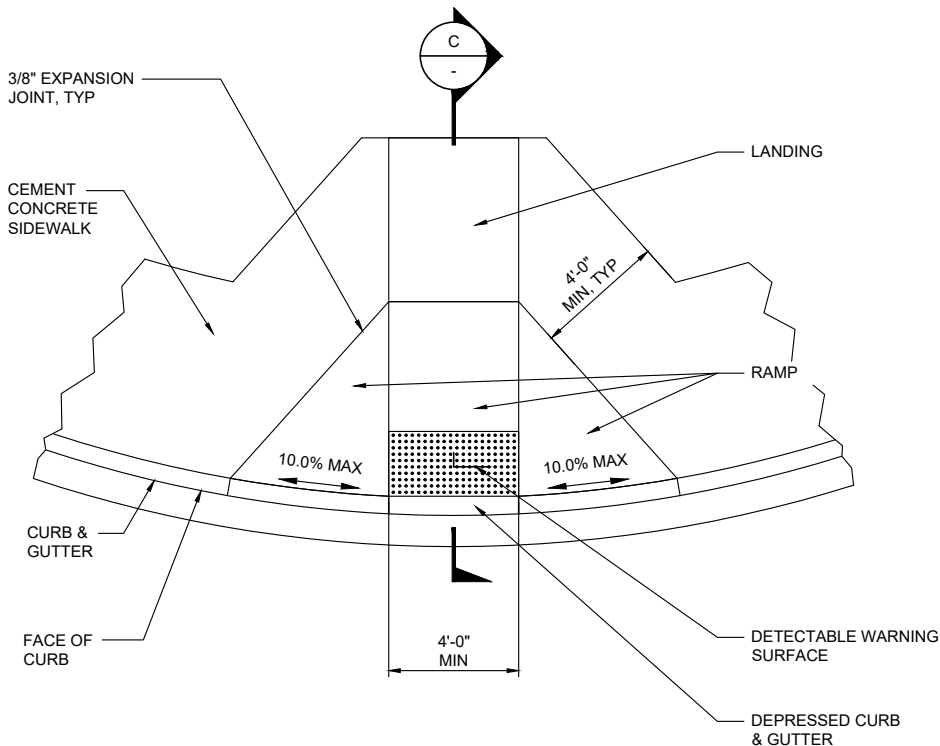

SECTION C
NTS

NOTES:

1. PROVIDE A SEPARATE CURB RAMP FOR EACH MARKED OR UNMARKED CROSSWALK. CURB RAMP LOCATION SHALL BE PLACED WITHIN THE WIDTH OF THE ASSOCIATED CROSSWALK.
2. WHERE "GRADE BREAK" IS CALLED OUT, THE ENTIRE LENGTH OF THE GRADE BREAK BETWEEN THE TWO ADJACENT SURFACE PLANES SHALL BE FLUSH.
3. DO NOT PLACE GRATINGS, JUNCTION BOXES, ACCESS COVERS, OR OTHER APPURTENANCES IN FRONT OF THE CURB RAMP OR ON ANY PART OF THE CURB RAMP OR LANDING.
4. THE CURB RAMP MAXIMUM RUNNING SLOPE SHALL NOT REQUIRE THE RAMP LENGTH TO EXCEED 15 FEET TO AVOID CHASING THE SLOPE INDEFINITELY WHEN CONNECTING TO STEEP GRADES. WHEN APPLYING THE 15 FOOT MAX LENGTH, THE RUNNING SLOPE OF THE CURB RAMP SHALL BE AS FLAT AS FEASIBLE.
5. CURB RAMP, LANDING, & FLARES SHALL RECEIVE BROOM FINISH.
6. DETECTABLE WARNING SURFACE SHALL MEET REQUIREMENTS OF WSDOT STANDARD DETAIL F45.10-02.

M:\ROS\YN\23867 Construction Standards Update\Figures\STREET\ST-7.dwg, 10/12/2024 11:57 AM, FRANK PARKER



CITY OF ROSLYN
CONSTRUCTION STANDARDS
DETAIL ST-7
PERPENDICULAR SIDEWALK
RAMP

Gray & Osborne, Inc.
 CONSULTING ENGINEERS

M:\ROSLYN\23867 Construction Standards Update\Figures\STREET\ST-8.dwg, 10/12/2024 11:57 AM, FRANK PARKER

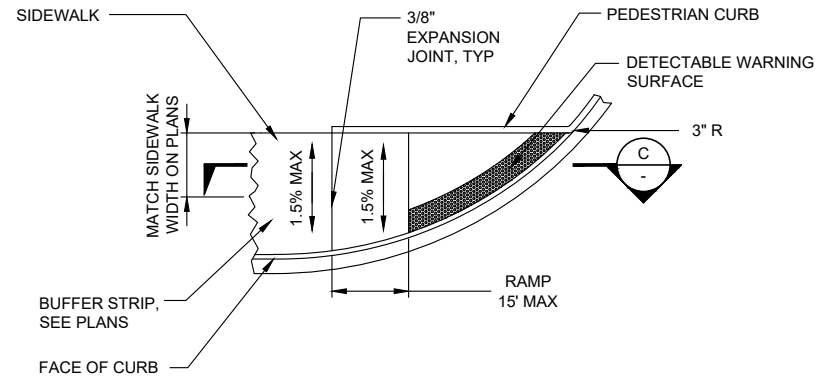
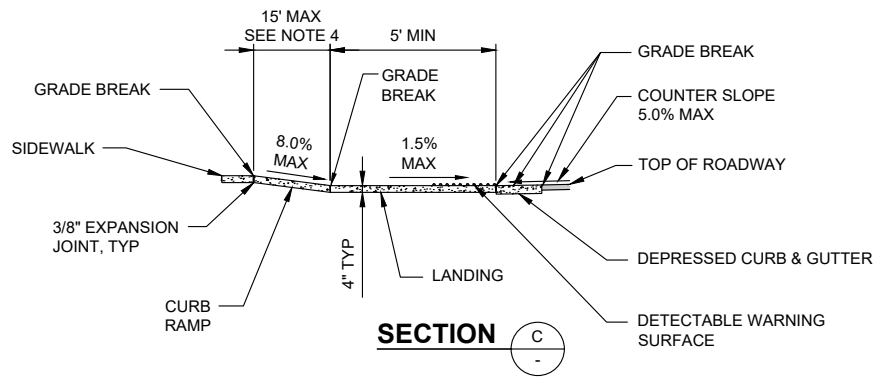

NOTES

1. PROVIDE A SEPARATE CURB RAMP FOR EACH MARKED OR UNMARKED CROSSWALK. CURB RAMP LOCATION SHALL BE PLACED WITHIN THE WIDTH OF THE ASSOCIATED CROSSWALK.
2. WHERE "GRADE BREAK" IS CALLED OUT, THE ENTIRE LENGTH OF THE GRADE BREAK BETWEEN THE TWO ADJACENT SURFACE PLANES SHALL BE FLUSH.
3. DO NOT PLACE GRATINGS, JUNCTION BOXES, ACCESS COVERS, OR OTHER APPURTENANCES IN FRONT OF THE CURB RAMP OR ON ANY PART OF THE CURB RAMP OR LANDING.
4. THE CURB RAMP MAXIMUM RUNNING SLOPE SHALL NOT REQUIRE THE RAMP LENGTH TO EXCEED 15 FEET TO AVOID CHASING THE SLOPE INDEFINITELY WHEN CONNECTING TO STEEP GRADES. WHEN APPLYING THE 15 FOOT MAX LENGTH, THE RUNNING SLOPE OF THE CURB RAMP SHALL BE AS FLAT AS FEASIBLE.
5. CURB RAMP, LANDING, & FLARES SHALL RECEIVE BROOM FINISH.
6. DETECTABLE WARNING SURFACE SHALL MEET REQUIREMENTS OF WSDOT STANDARD DETAIL F45.10-02.



CITY OF ROSLYN
CONSTRUCTION STANDARDS
DETAIL ST-8
SINGLE DIRECTION CURB RAMP



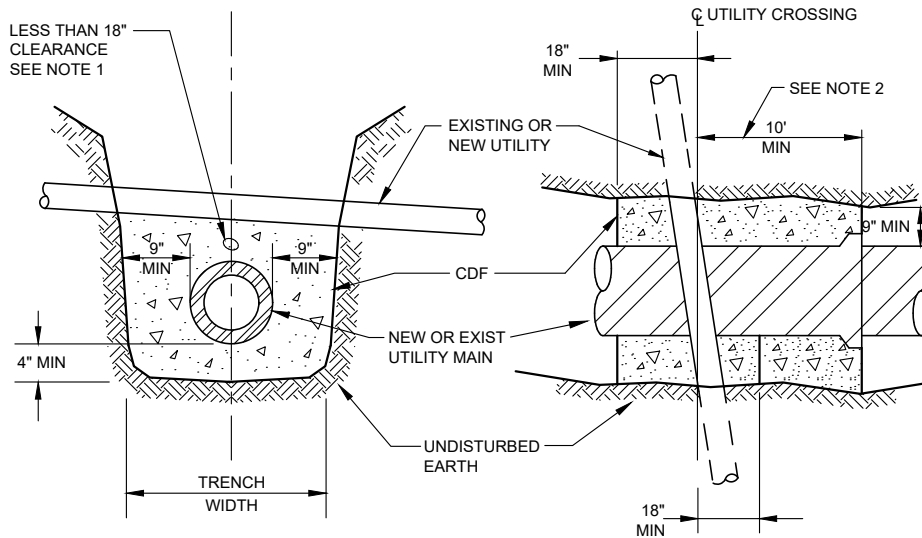

NOTES:

1. CONTRACTOR SHALL PROVIDE CONTROLLED DENSITY FILL PIPE ENCASEMENT AT ALL EXISTING UTILITY CROSSINGS IN THE EVENT THAT AN 18" SEPARATION CANNOT BE PROVIDED. THE CONTRACTOR SHALL FAMILIARIZE THEMSELVES WITH THE SITE UTILITIES TO ANTICIPATE PROVIDING AND INSTALLING CONCRETE ENCASEMENTS WHERE NECESSARY. THIS SHALL ALSO APPLY AT NEW STORM DRAIN STRUCTURES NEAR EXISTING WATER MAINS. SEE DEPARTMENT OF ECOLOGY CRITERIA FOR SEWAGE WORKS DESIGN SECTION C1-9.1 AND THE DEPARTMENT OF HEALTH WATER SYSTEM DESIGN MANUAL SECTION 8.4.4.
2. CONTRACTOR SHALL NOT CONSTRUCT ANY NEW PIPE JOINT WITHIN 10 FEET OF THE EXISTING CENTERLINE OF THE UTILITY CROSSING.

M:\ROSLYN\23867 Construction Standards Update\Figures\STREET\ST-9.dwg, 10/12/2024 11:57 AM, FRANK PARKER



CITY OF ROSLYN
 CONSTRUCTION STANDARDS
DETAIL ST-9
TYPICAL UTILITY CROSSING



Gray & Osborne, Inc.
 CONSULTING ENGINEERS

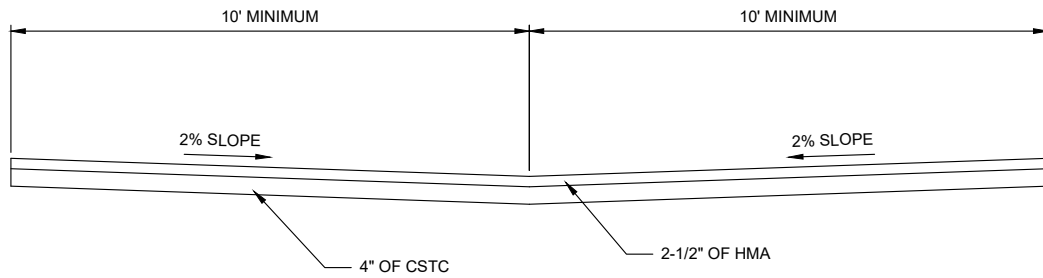
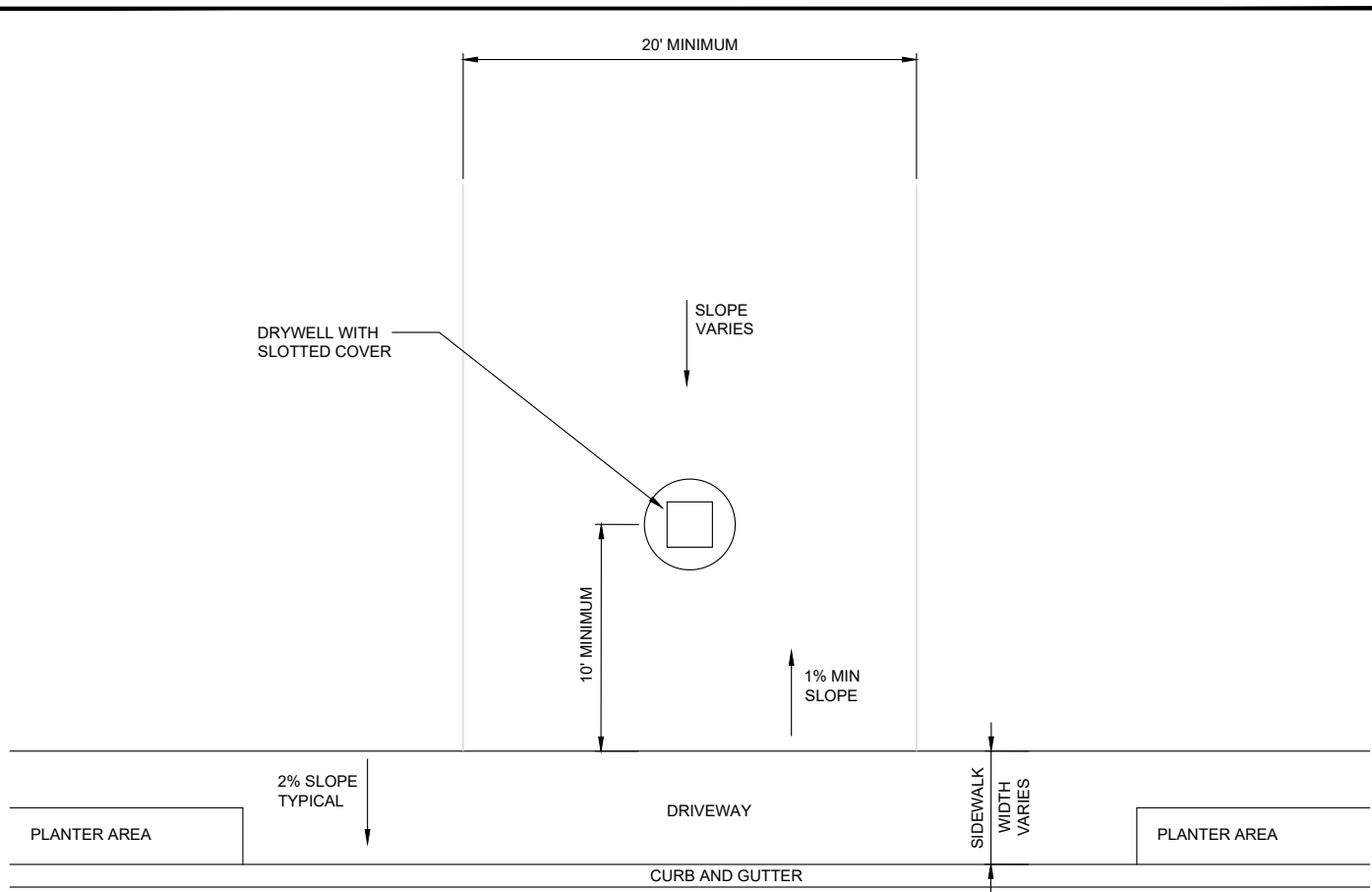

NOTES:

1. ALLEYS IN RESIDENTIAL AREAS SHALL BE GRADED AND HAVE 4" CSTC. RESIDENTIAL DEVELOPMENT DEVIATION REQUEST MAY REQUIRE PAVED ALLEYS IN ACCORDANCE WITH THIS DETAIL.
2. ALLEYS ADJACENT TO PROPERTIES OTHER THAN RESIDENTIAL AREAS SHALL BE AS SHOWN IN THIS DETAIL.
3. PAVED ALLEYS SHALL HAVE A CENTERLINE SLOPE OF 0.5% OR GREATER.
4. ALL CONSTRUCTION AND MATERIALS SHALL MEET THE WSDOT SPECIFICATIONS AND BE APPROVED BY THE CITY.



CITY OF ROSLYN
 CONSTRUCTION STANDARDS
DETAIL ST-10
TYPICAL ALLEY



Gray & Osborne, Inc.
 CONSULTING ENGINEERS

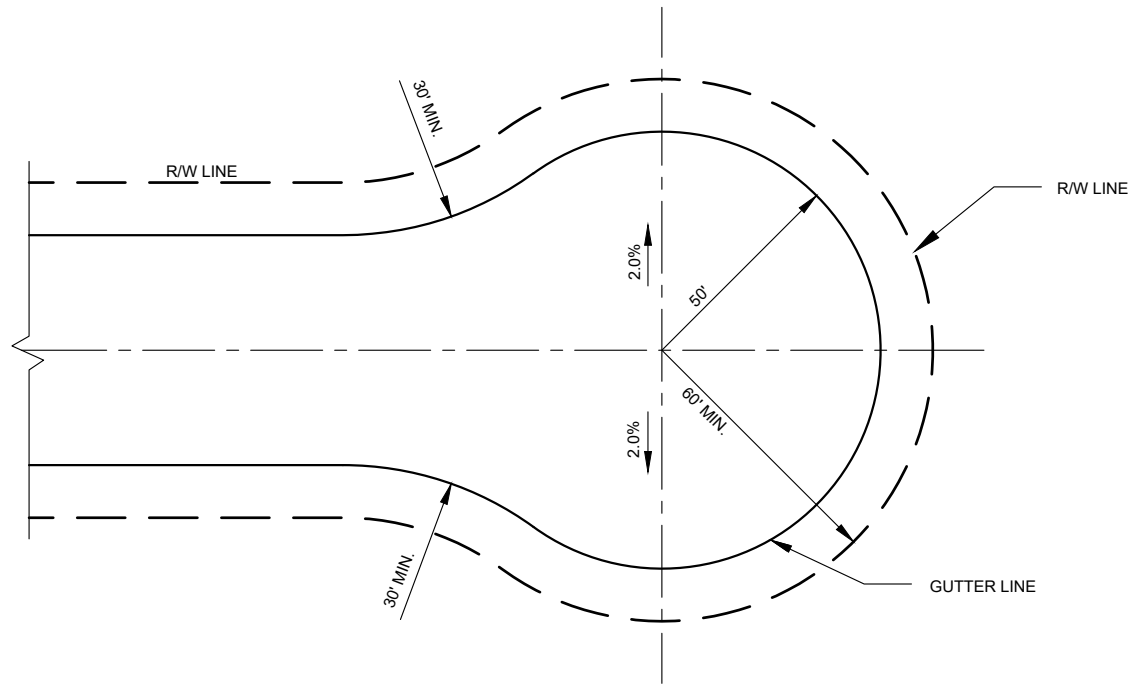

NOTE:

ALTERNATIVE DEAD-END STREET DESIGNS SHALL BE IN ACCORDANCE WITH THE INTERNATIONAL FIRE CODE, AS OUTLINED IN APPENDIX D, FIRE APPARATUS ACCESS ROADS, AND SHALL BE SUBJECT TO APPROVAL BY THE CITY.

M:\ROSLYN\23867 Construction Standards Update\Figures\STREET\ST-11.dwg, 10/1/2024 11:59 AM, FRANK PARKER



CITY OF ROSLYN
CONSTRUCTION STANDARDS
DETAIL ST-11
CUL-DE-SAC STANDARD



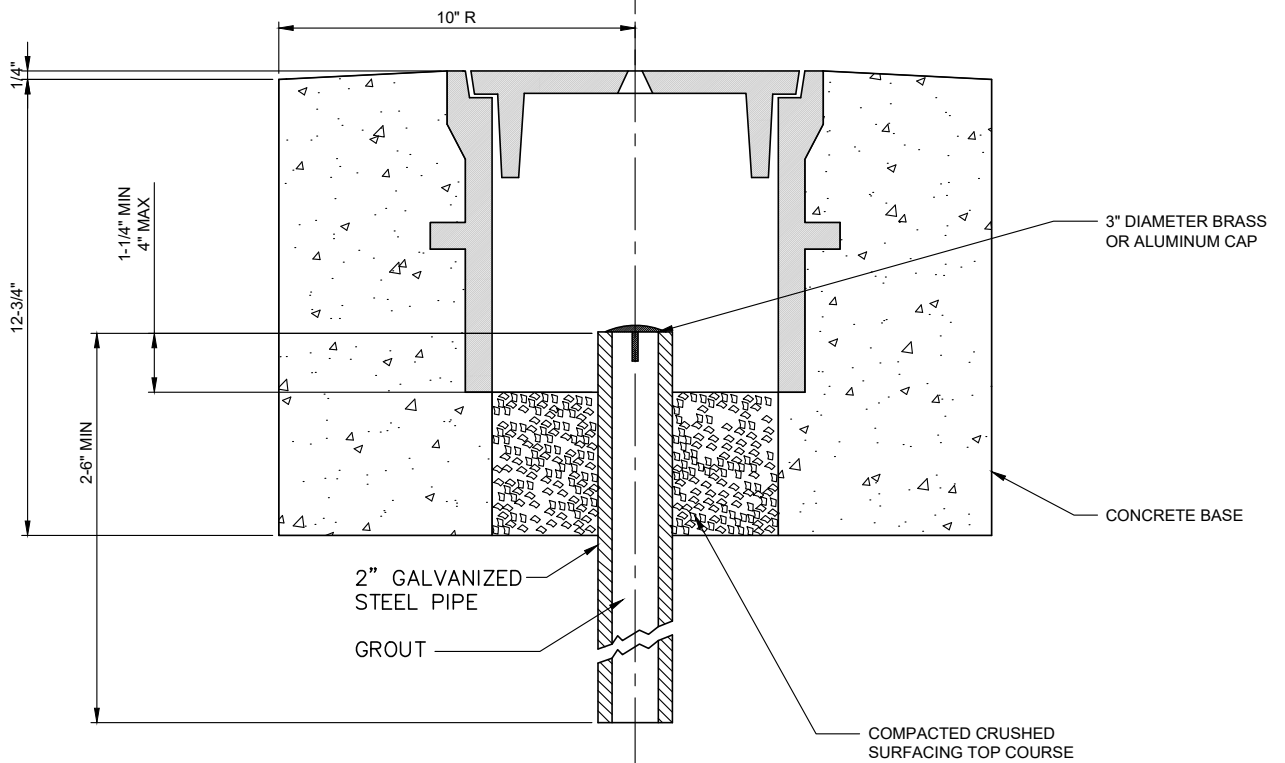
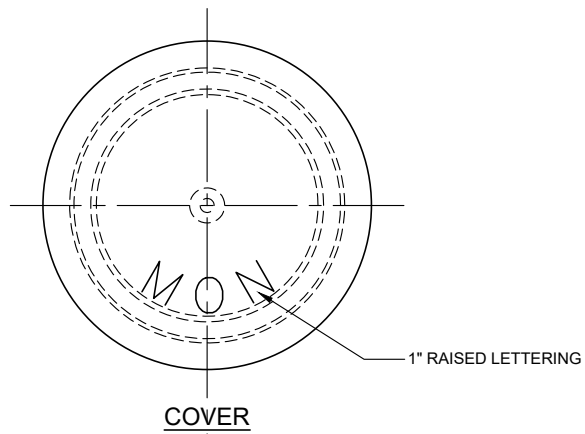

SECTION

M:\ROSLYN\23867 Construction Standards Update\Figures\STREET\ST-12.dwg, 10/1/2024 11:59 AM, FRANK PARKER



CITY OF ROSLYN
 CONSTRUCTION STANDARDS
DETAIL ST-12
MONUMENT CASE AND COVER



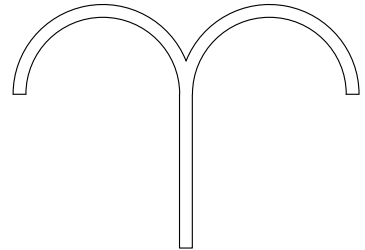
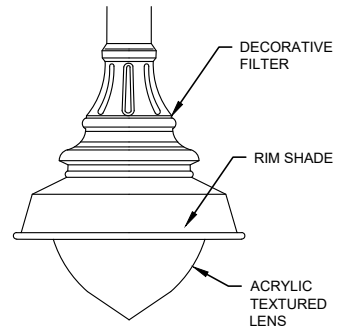
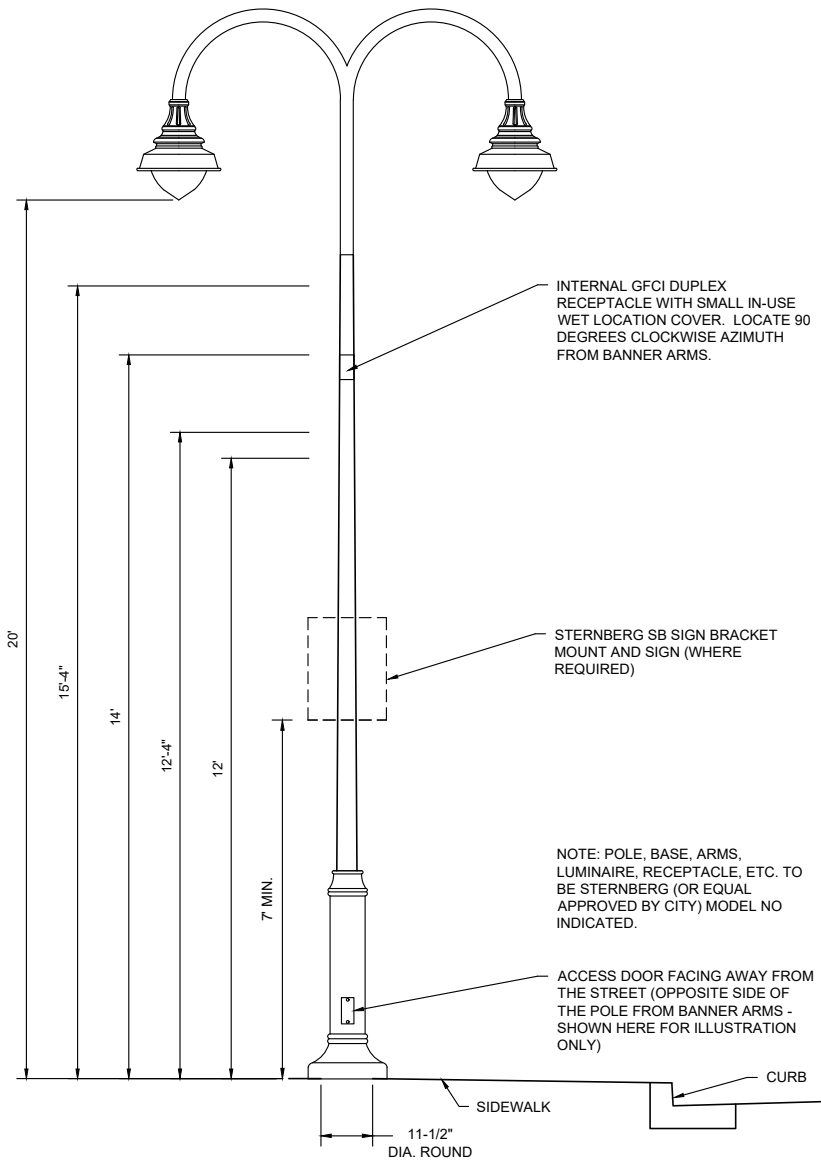

SPECIFICATIONS:
 MAKE, MODEL: STERNBERG RPM2
 DIMENSIONS 63" HIGH X 60" WIDE

LUMINAIRE BRACKET

NOTE: POLE, BASE, ARMS, LUMINAIRE, RECEPTACLE, ETC. TO BE STERNBERG (OR EQUAL APPROVED BY CITY) MODEL NO INDICATED.

ORNAMENTAL LIGHT STANDARD

SPECIFICATIONS:
 MAKE, MODEL: STERNBERG 1910 LED/5RLM PARK RIDGE SERIES
 PART NO.: 2-1910LED/5LBS/RPM/PTP/33-00-RT6-30AG/4A1R60T5/ML/BK
 LIGHT SOURCE: LED-4A1R60T5
 GLOBE MATERIAL: DENT RESISTANT ACRYLIC
 IES CLASSIFICATION: TYPE III
 WATTAGE: 97W
 COLOR TEMP: 3500K
 VOLTAGE: AUTO-SENSING VOLTAGE (120-277 VOLTS)
 PAINT: WEATHERED BROWN

M:\ROS\YN\23867 Construction Standards Update\Figures\STREET\ST-13.dwg, 10/18/2024 11:26 AM, FRANK PARKER



CITY OF ROSLYN
 CONSTRUCTION STANDARDS
DETAIL ST-13
ORNAMENTAL LIGHTING

Gray & Osborne, Inc.
 CONSULTING ENGINEERS

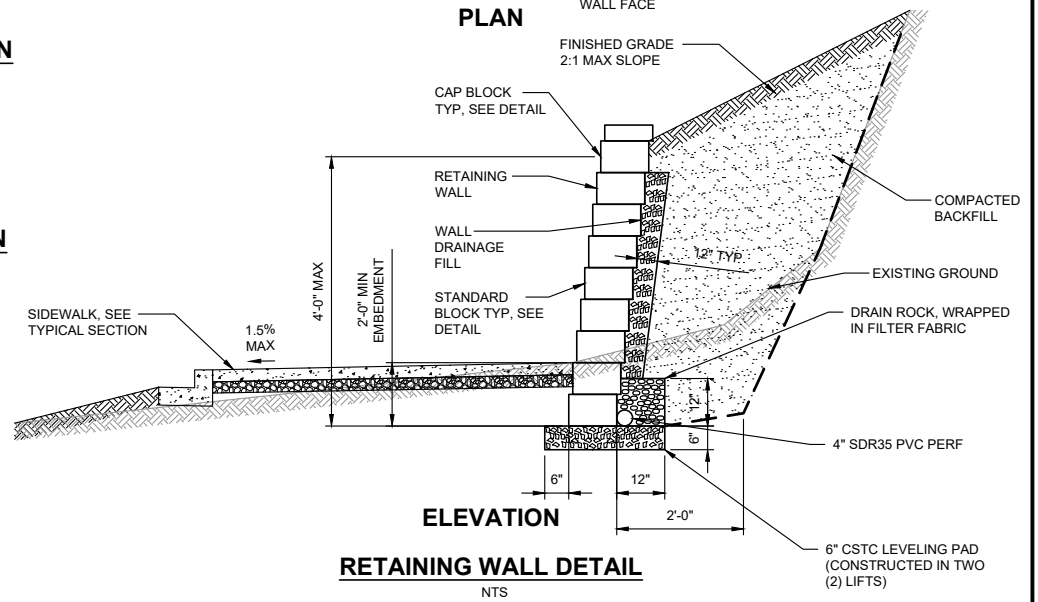
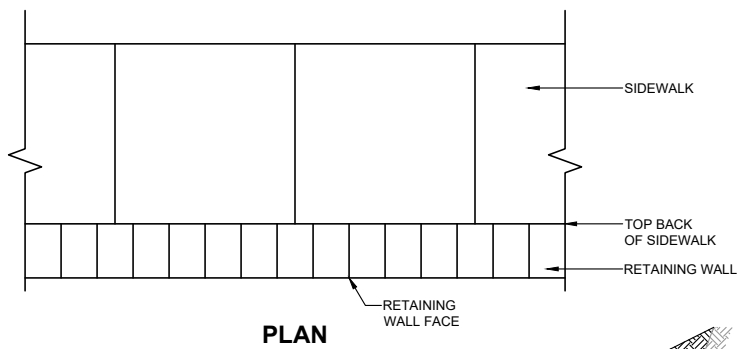
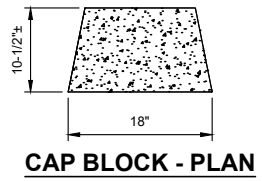
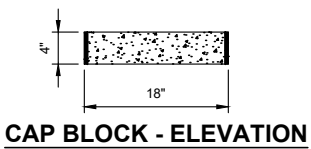
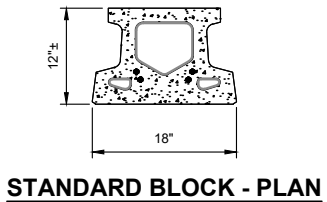
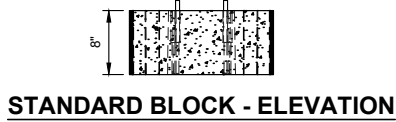

M:\ROSLYN\23867 Construction Standards Update\Figures\STREET\ST-14.dwg, 10/1/2024 11:59 AM, FRANK PARKER



CITY OF ROSLYN
CONSTRUCTION STANDARDS
DETAIL ST-14
RETAINING WALL DETAIL

Gray & Osborne, Inc.
CONSULTING ENGINEERS

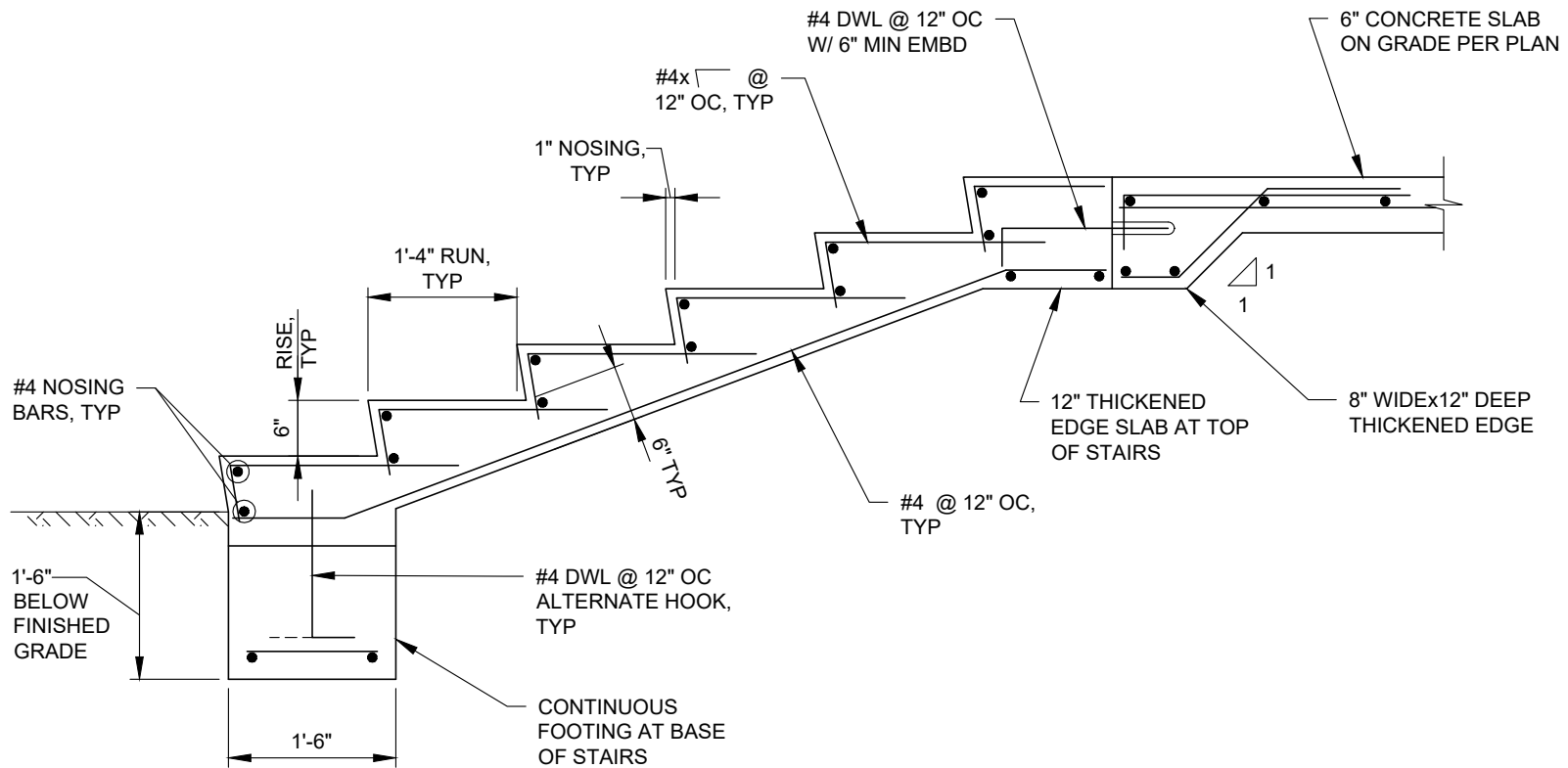

CONCRETE STAIR DETAIL

CITY OF ROSLYN
 CONSTRUCTION STANDARDS
DETAIL ST-15
CONCRETE STAIR DETAIL



**POWDER COATED COLOR:
FOREST SERVICE BROWN**
ALUMINUM HANDRAIL -
PIPE 1 1/2 STD, TYP

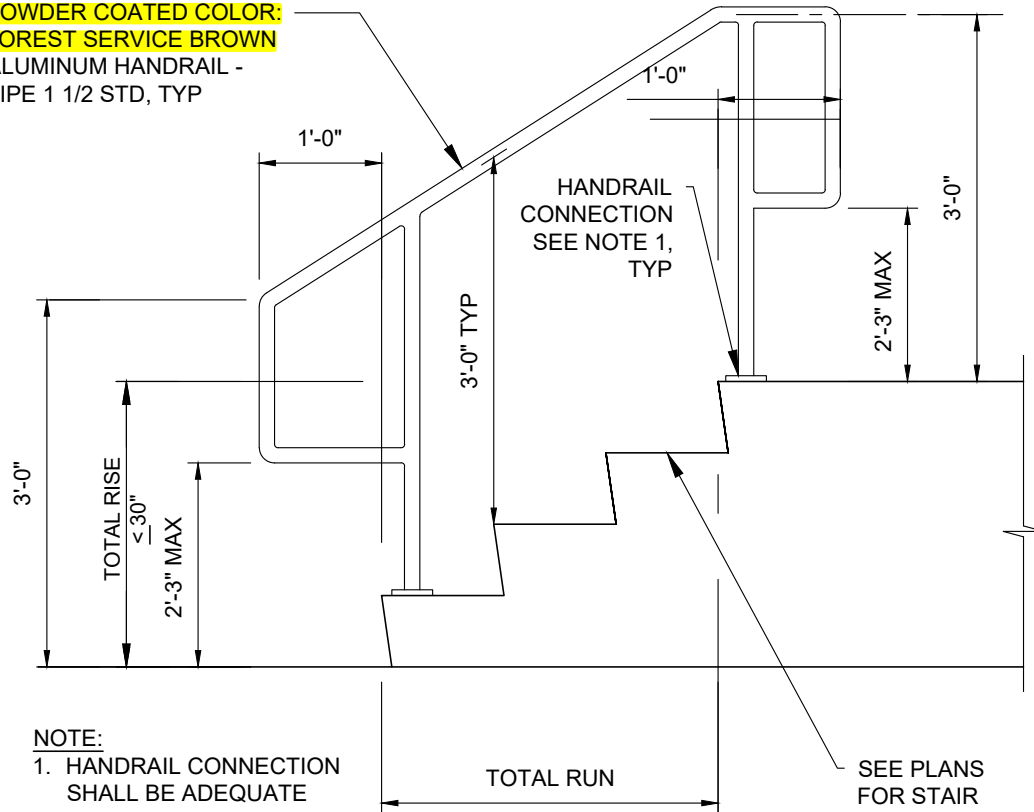

NOTE:
1. HANDRAIL CONNECTION
SHALL BE ADEQUATE
FOR LOADS REQUIRED
BY IBC.

SEE PLANS
FOR STAIR
GEOMETRY
AND DETAILS

HANDRAIL DETAIL

CITY OF ROSLYN
CONSTRUCTION STANDARDS

DETAIL ST-16
HANDRAIL DETAIL

Gray & Osborne, Inc.
CONSULTING ENGINEERS

